



UGS 025/355 ADAPTER FLEX.

Item no. 4356

Document type: **Product card**
Document date: **2019-05-21**
Generated by: **Systemair Online Catalogue**

Description

Adaptor flexible square to circular

Reduction from square to round. The frame is manufactured from aluminium and neoprene coated fabric. For temperature up to 60°C. The circular side has a locking ring for easy installation to the duct system.

Suitable for MUB and K.. airhandling units.

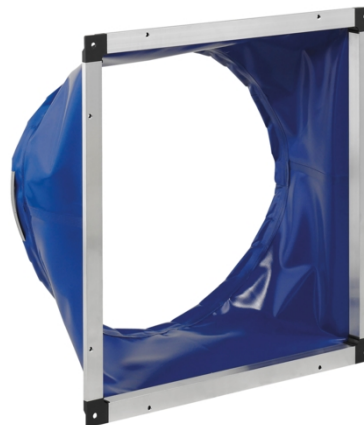

Technical parameters

Other	
Weight	1 kg

Get In Touch

Call: [0845 6880112](tel:08456880112)
 Email: info@adremit.co.uk

Our Address

Puravent, Adremit Limited, Unit 5a, Commercial Yard,
Settle, North Yorkshire, BD24 9RH



Dimensions

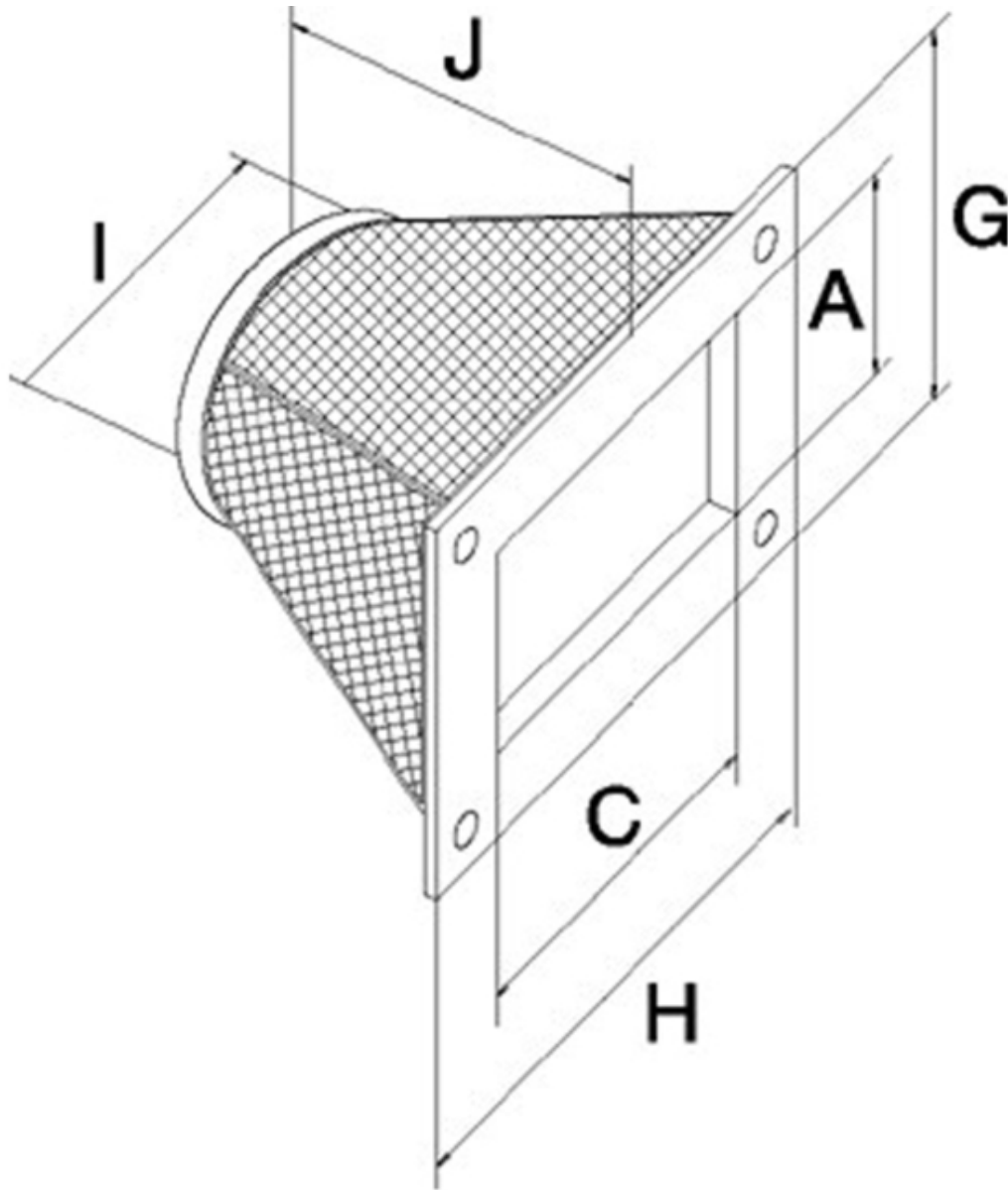

A/C	G/H	I	J
UGS 025/355	358	418	355 210

Accessories

Documentation

Specification text

Name: **UGS 025/355 ADAPTER FLEX.** | Item no.: **4356**

Document type: **Product card** | Document date: **2019-05-21** | Generated by: **Online catalogue**

2 / 2

Get In Touch



Call: [0845 6880112](tel:08456880112)



Email: info@adremit.co.uk

Our Address

Puravent, Adremit Limited, Unit 5a, Commercial Yard,
Settle, North Yorkshire, BD24 9RH