

TUNE-S

Rectangular control damper



Ordering codes:

Size (mm)	200 - 1200 × 100 - 1000 (W × H)	TUNE-S -
handle		H
preparation for actuator		M0
230V actuator		M1
24V actuator		M2
24V, 0-10V stepless actuator		M3
230V spring actuator		M4
24V spring actuator		M5
Version	24V, 0-10V stepless spring actuator	M6

Ordering code example:

TUNE-S - 600×200 - M3

TUNE-S ,with 600 mm width and 200 mm height drive 24V power supply, continuous control signal DC 0-10 V.

Description

Tune-S is a control and shut off damper for rectangular ducts. It is available in with blade tightness class C3 or C4 depending on the size, tested according to EN 1751. It is ideal for use as a control and shut-off damper where different parts of the system need to be airtight separated from each other because of the dangerous materials contained in the air (surgery rooms). It can also be used as a shut-off damper for air handling units, combined with a spring return actuator. In case of power outage the damper can maintain a fully closed position. The damper's special construction allows external insulation up to 50 mm. The damper can be supplied in a manual or motorized version with an integrated position indicator. The maximum allowed temperature is 100°C. The maximum duct pressure is 1000 Pa.

Design

TUNE-S units are constructed from sheet steel frame and Aluminium profile blades. The frame construction contains a robust flanged mounting frame to assure the sturdiness of the unit and to facilitate the mounting to upstream and downstream ducts.

The aerofoil blades are opposed action and are constructed from extruded aluminium and enforce corrosionfree throughout the blade to add rigidity and reduce the pressure loss and sound levels which may be contributed to airflow stream passing over the blades. The blades are equipped by rubber gaskets eliminating leakage in closed position. The blade axe are sitting in self lubricating bearings which are connected together by a gear wheel - rod combination to assure a smooth ratio and transition from blade to blade. The pressure difference averaging measuring cross is applied for a precise flow measurement and control.

Available sizes:

200 × 100 mm to 1200 × 1000 mm with steps of 50 mm in height and length

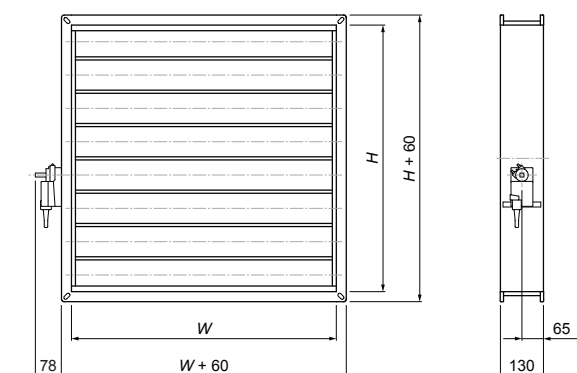

Fig. 1: TUNE-S dimensions

Get In Touch

Call: 0845 6880112
 Email: info@adremit.co.uk

Our Address

Puravent, Adremit Limited, Unit 5a, Commercial Yard,
 Settle, North Yorkshire, BD24 9RH

Dimensions

H \ W	200	250	300	350	400	450	500	550	600	650	700	750	800	850	900	950	1000	1050	1100	1150	1200	
100	2,5	2,5	3	3	3	3,5	3,5	3,5	4													
150	3	3	3	3,5	3,5	4	4	4	4,5	4,5												
200	3,5	3,5	3,5	3,5	3,5	4	4	4	4,5	4,5	4,5	4,5	5	5	5,5							
250		4,5	4	4	4	4	4,5	4,5	4,5	5	5	5	5	5,5	6							
300		3C	5	5	5	5	5	5	5	5,5	5,5	5,5	5,5	5,5	6	6	6	6,5	6,5			
350		4C	5	5,5	5,5	5,5	5,5	5,5	5,5	5,5	5,5	5,5	5,5	5,5	6	6	6	6,5	6,5	7		
400					6	6	6	6	6	6	6	6	6	6	6,5	6,5	6,5	6,5	7	7,5	8	
450						7	7	7	7	7	7	7	7	7	7	7	7	7	7,5	8	9	
500							8	8	8	8	8	8	8	8	8	8	8	8	8	9	9,5	
550								8	8	8	8	7	7	7	7,5	8	8	8	9	9	9,5	10
600									8	8	8	8	8	8	8,5	8	9	9	9,5	10	10,5	11
650										8	8	8	8	8	8,5	9	9	9,5	10	10,5	11	
700											8,5	8,5	8,5	8,5	9	9,5	9,5	10	10,5	11	12	
750												9	9	9	9,5	10	10	10,5	11	12	13	
800													9	10	10	10,5	10,5	11	12	13	14	
850														10	11	11	11,5	12	13	14	15	
900															11	12	12	13	14	15	16	
950																13	13	14	15	16	17	
1000																	14	15	16	17	18	

Tab. 1: TUNE-S table of sizes and max. weight with actuator

<i>m</i> (kg)	5 Nm actuator
<i>m</i> (kg)	10 Nm drive
<i>m</i> (kg)	20 Nm drive

Mounting

Tune-S is mounted into the ductwork by a standard flange. The fixing bolts, nuts, clips and gaskets shall be delivered by the installation company.

The damper cannot be installed carrying any mechanical loads from other structures.

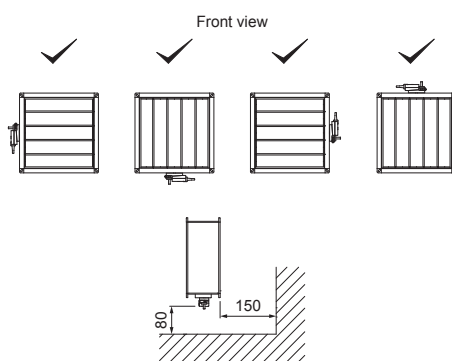

Fig. 2: TUNE-S Installation positioning.

NOTE:

A proper flange fixing method (e.g. flange clamps) and gasket shall be used by installer to maintain the corresponding tightness class.

TPI-45 Systemair 11 / 2013



Get In Touch

Call: 0845 6880112
 Email: info@adremit.co.uk

Our Address

Puravent, Adremit Limited, Unit 5a, Commercial Yard, Settle, North Yorkshire, BD24 9RH

