



## The most versatile hot water air heater on the market

The TANNER MDA is a water-supplied suspended air heater which can expel air horizontally or vertically. The unit has a powerful axial fan which means it is suitable for many applications. Mark offers a highly extensive range of accessories for the TANNER MDA allowing it to be aligned to all applications. For example, the unit can be made suitable for external air connection in combination with filtering and a mixing box for the destratification of fresh external air. The unit is also available as an ATEX / EEX-model. (400V) - IP 44 (EX II 2 G EEX e II T3).

The TANNER MDA is designed for use in showrooms, changing rooms, corporate hallways and garages.

#### Features:

- Manufactured with a corrosion-resistant aluzinc housing as standard
- Copper/aluminium heat exchanger
- Highly versatile due to extensive configuration options
- Available as 230V or 400V
- IP class 54

There is also a TANNER MDA+ with integrated drip tray available that is suitable for both heating and cooling

Optional: speed controlled low noise EC-motor (230V/0-10V). Advantages:

- The highest efficiency in case of speed control
- Up to 50% energy saving in case of partial load
- Almost completely linearly adjustable
- Long lifetime
- Low noise level
- Integrated electronic thermal protection



Remote connection possible with the PinTherm Connect!

# mark®

#### Get In Touch



Call: [0845 6880112](tel:08456880112)



Email: [info@adremit.co.uk](mailto:info@adremit.co.uk)

#### Our Address

Puravent, Adremit Limited, Unit 5a, Commercial Yard, Settle, North Yorkshire, BD24 9RH

# Dimensions

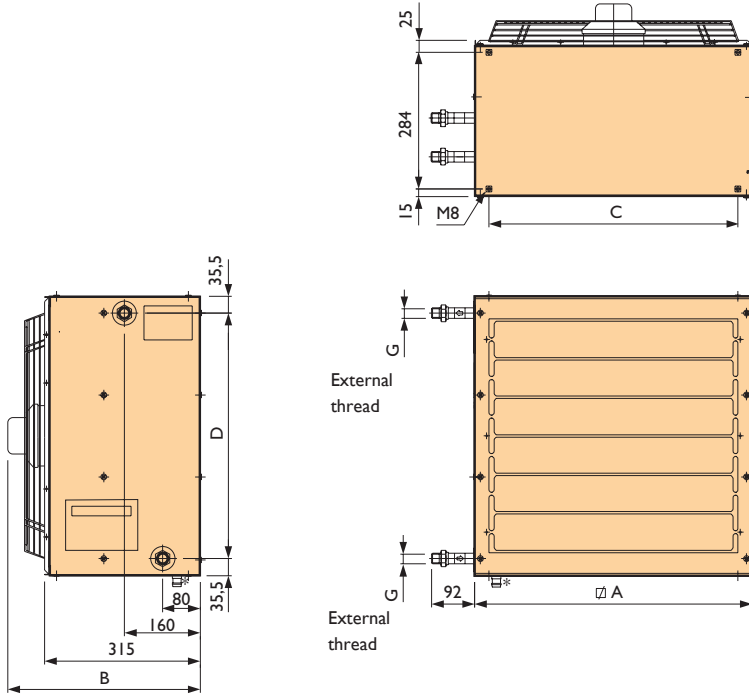

Type	A	B	C	D	1R	2R	3R	4R
100	450	380	387	379	1"	1"	1"	1"
200	580	385	517	509	1"	1"	1"	1"
300	730	385	667	659	1"	1"	1 1/4"	1 1/4"
400	860	405	797	789	1"	1 1/4"	1 1/2"	1 1/2"

\* Condensate connection  $\varnothing$  20 mm. Only for Tanner MDA+ for heating/cooling.

## Technical information

### TYPE DESIGNATION

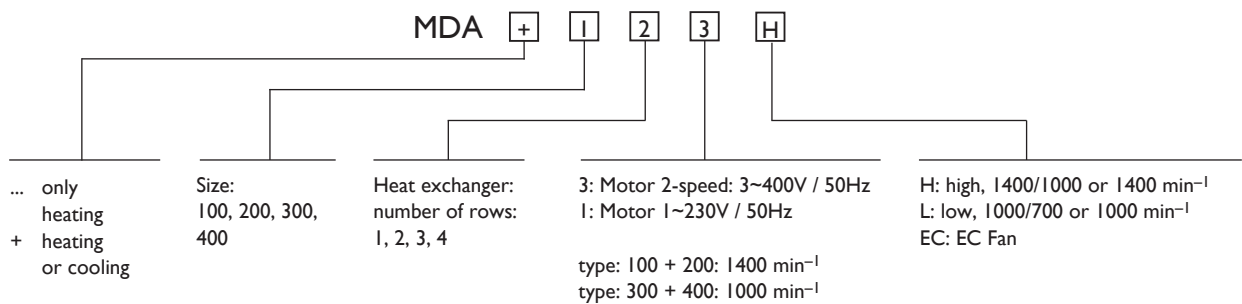

### Get In Touch

Call: 0845 6880112  
Email: [info@adremit.co.uk](mailto:info@adremit.co.uk)

### Our Address

Puravent, Adremit Limited, Unit 5a, Commercial Yard, Settle, North Yorkshire, BD24 9RH

Type		121L	131L	141L	211L	221L	231L	241L	321L*	331L*	341L*	411L*	421L*	431L*	441L*
90/70 T 15	kW	14,5	17,0	19,0	14,1	25,1	30,8	33,3	52,7	65,9	72,1	42,5	80,0	101,0	110,0
Water resistance T15	kPa	4	8	12	5	7	4	8	8	4	12	8	8	6	18
Outlet temperature at the heat exchanger	°C	41,7	49,4	59,2	29,8	42,7	53,0	58,8	38,8	48,0	54,0	28,3	38,6	48,6	54,1
80/60 T 15	kW	11,9	14,1	15,9	11,6	20,6	25,4	27,8	43,3	54,1	60,2	34,9	65,7	83,1	91,6
Outlet temperature at the heat exchanger	°C	36,8	43,6	52,0	27,1	37,8	46,3	51,6	34,6	42,1	47,6	26,0	34,4	42,7	47,7
60/40 T 15	kW	6,6	8,3	9,6	6,6	11,7	14,4	16,7	24,4	30,2	35,8	20,0	36,9	47,2	55,1
Outlet temperature at the heat exchanger	°C	27,1	31,7	37,3	21,9	27,9	32,8	36,9	26,0	30,1	34,4	21,3	25,9	30,7	34,7
7/12 T 28 °C [RH50%]**	kW	3,6	4,37	6,15	-	6,32	7,71	10,4	13,3	16,4	22,3	-	20,1	25,4	35,4
Blow-out temperature**	°C	21,1	18,8	17,2	-	20,7	18,1	17,2	21,8	19,5	18,2	-	21,8	19,2	18,3
Water resistance T28**	kPa	6	12	24	-	8	5	14	11	7	22	-	10	8	38
Speed	rpm	900	900	900	830	830	830	830	845	845	845	925	925	925	925
Air displacement	m <sup>3</sup> /h	1595	1446	1265	2805	2656	2381	2233	6495	5857	5423	10320	9933	8816	8217
Noise at 5 m	dB(A)	49	49	49	50	49	48	48	52	53	53	63	61	59	58
Weight without accessories	kg	22	23	24	30	32	34	36	43	46	49	51	55	59	63
Horizontal throw	m	12	10	8	19	17	15	12	25	22	19	38	35	31	27
Vertical throw	m	4	4	3,5	6,2	4,8	4,5	4	8,1	6,8	5,9	7,5	7,4	6,2	5,5
Consumed current (AC fan)	A	0,35	0,35	0,35	0,49	0,49	0,49	0,49	1,5	1,5	1,5	1,8	1,8	1,8	1,8
Consumed current (EC fan)	A	-	-	-	-	-	-	-	1,65	1,65	1,65	2,7	2,7	2,7	2,7
Nominal electric power (AC fan)	kW	0,077	0,077	0,077	0,113	0,113	0,113	0,113	0,33	0,33	0,33	0,4	0,4	0,4	0,4
Nominal electric power (EC fan)	kW	-	-	-	-	-	-	-	0,24	0,24	0,24	0,62	0,62	0,62	0,62

Type		121H*	131H*	141H*	211H*	221H*	231H*	241H*
90/70 T 15	kW	18,0	22,1	25,1	17,2	32,4	42,0	46,6
Water resistance T15	kPa	7	13	20	7	9	5	13
Outlet temperature at the heat exchanger	°C	37,4	43,9	53,4	27,1	37,6	46,4	51,6
80/60 T 15	kW	14,7	18,3	20,9	14,1	26,6	34,5	38,7
Outlet temperature at the heat exchanger	°C	33,3	38,9	47,1	25,0	33,6	40,8	45,5
60/40 T 15	kW	8,1	10,6	12,5	8,1	14,9	19,3	22,9
Outlet temperature at the heat exchanger	°C	25,0	28,8	34,2	20,7	25,4	29,4	33,0
7/12 T 28 °C [RH50%]**	kW	4,46	5,67	7,88	-	8,14	10,5	14,1
Blow-out temperature**	°C	22,2	20,3	18,3	-	22,1	19,9	16,9
Water resistance T28**	kPa	10	16	37	-	12	7	25
Speed	rpm	1400	1400	1400	1400	1400	1400	1400
Air displacement	m <sup>3</sup> /h	2365	2244	1914	4450	4202	3932	3734
Noise at 5 m	dB(A)	54	55	55	58	57	53	53
Weight without accessories	kg	22	23	24	30	32	34	34
Horizontal throw	m	15	13	11	22	20	19	17
Vertical throw	m	6,9	6,8	6,3	8,8	7,7	7,6	7,2
Consumed current (AC fan)	A	0,6	0,6	0,6	1,15	1,15	1,15	1,15
Consumed current (EC fan)	A	0,98	0,98	0,98	2,2	2,2	2,2	2,2
Nominal electric power (AC fan)	kW	0,13	0,13	0,13	0,23	0,23	0,23	0,23
Nominal electric power (EC fan)	kW	0,125	0,125	0,125	0,32	0,32	0,32	0,32

\* Available with speed controlled EC-motor.  
 \*\* Only for Tanner MDA+ for heating/cooling.

Hot water-supplied air heaters - 44

## Get In Touch

Call: 0845 6880112  
 Email: [info@adremit.co.uk](mailto:info@adremit.co.uk)

## Our Address

Puravent, Adremit Limited, Unit 5a, Commercial Yard,  
 Settle, North Yorkshire, BD24 9RH

MDA low-speed - 3 phase 400V

Type		123L	133L	143L	213L	223L	233L	243L	323L	333L	343L	413L	423L	433L	443L	
heating	90/70 T 15	kW	14,5	17,0	19,0	14,8	26,2	32,4	35,1	52,7	65,9	72,1	45,2	84,0	107,0	117,0
	Water resistance T15	kPa	4	8	12	5	6	4	9	8	4	12	9	9	7	21
	Outlet temperature at the heat exchanger	°C	41,7	49,4	59,2	29,2	41,9	52,0	57,7	38,8	48,0	54,0	27,5	37,7	47,3	52,7
heating	80/60 T 15	kW	11,9	14,1	15,9	12,1	21,6	26,7	29,3	43,3	54,1	60,2	37,1	68,9	88,1	97,4
	Outlet temperature at the heat exchanger	°C	36,8	43,6	52,0	26,7	37,1	45,4	50,6	34,6	42,1	47,6	25,3	33,6	41,6	46,5
	60/40 T 15	kW	6,6	8,3	9,6	7,0	12,2	15,1	17,5	24,4	30,2	35,8	21,2	38,7	49,9	58,5
cooling	Outlet temperature at the heat exchanger	°C	27,1	31,7	37,3	21,7	27,5	32,2	33,3	26,0	30,1	34,4	20,9	25,4	30,1	34,0
	7/12 T 28 °C [RH50%] **	kW	3,6	4,37	6,15	-	6,6	8,1	10,9	13,3	16,4	22,3	-	21,1	26,9	37,5
	Blow-out temperature **	°C	21,1	18,8	17,2	-	21	18,4	17,6	21,8	19,5	18,2	-	22,1	19,6	18,4
cooling	Water resistance T28 **	kPa	6	12	24	-	8	6	16	11	7	22	-	11	9	42
	Speed	rpm	1000	1000	1000	1000	1000	1000	1000	910	910	910	870	870	870	870
	Air displacement	m³/h	1595	1446	1265	3050	2865	2574	2414	6495	5857	5423	11600	10868	9735	9064
	Noise at 5 m	dB(A)	48	49	49	50	49	48	48	52	53	53	63	61	59	59
	Weight without accessories	kg	22	23	24	30	32	34	36	43	46	46	52	52	61	64
	Horizontal throw	m	12	10	8	19	17	15	13	25	22	19	38	35	31	28
	Vertical throw	m	4	4	3,5	6,8	5,9	4,5	4	8,1	6,8	5,9	9,4	8,5	6,9	5,8
	Consumed current	A	0,1	0,1	0,1	0,3	0,3	0,3	0,3	0,85	0,85	0,85	1,25	1,25	1,25	1,25
	Nominal electric power	kW	0,05	0,05	0,05	0,12	0,12	0,12	0,12	0,38	0,38	0,38	0,6	0,6	0,6	0,6

MDA high-speed - 3 phase 400V

Type		123H	133H	143H	213H	223H	233H	243H	
heating	90/70 T 15	kW	18,0	22,1	25,1	17,2	32,4	42,0	46,6
	Water resistance T15	kPa	7	13	20	7	9	5	13
	Outlet temperature at the heat exchanger	°C	37,4	43,9	53,4	27,1	37,6	46,4	51,6
heating	80/60 T 15	kW	14,7	18,3	20,9	14,1	26,6	34,5	38,7
	Outlet temperature at the heat exchanger	°C	33,3	38,9	47,1	25,0	33,6	40,8	45,5
	60/40 T 15	kW	8,1	10,6	12,5	8,1	14,9	19,3	22,9
cooling	Outlet temperature at the heat exchanger	°C	25,0	28,8	34,2	20,7	25,4	29,4	33,0
	7/12 T 28 °C [RH50%] **	kW	4,46	5,67	7,88	-	8,14	10,5	14,1
	Blow-out temperature **	°C	22,2	20,3	18,3	-	22,1	19,9	16,9
cooling	Water resistance T28 **	kPa	10	16	37	-	12	7	25
	Speed	rpm	1330	1330	1330	1350	1350	1350	1350
	Air displacement	m³/h	2365	2244	1914	4450	4202	3932	3734
	Noise at 5 m	dB(A)	54	55	55	58	57	53	53
	Weight without accessories	kg	22	23	24	30	32	34	36
	Horizontal throw	m	15	13	11	22	20	19	17
	Vertical throw	m	6,9	6,8	6,3	8,8	7,7	7,6	7,2
	Consumed current	A	0,36	0,36	0,36	0,51	0,51	0,51	0,51
	Nominal electric power	kW	0,16	0,16	0,16	0,216	0,216	0,216	0,216

\*\* Only for Tanner MDA+ for heating/cooling.

Capacity calculation for other water temperatures

ΔT1	ΔT2															
	20	25	30	35	40	45	50	55	60	65	70	75	80	85	90	95
10	0.26	0.35	0.44	0.53	0.62	0.71	0.80	0.89	1.04	1.14	1.23	1.34	1.44	1.54	1.64	1.74
15	0.22	0.31	0.39	0.49	0.58	0.67	0.77	0.85	0.96	1.06	1.17	1.26	1.36	1.46	1.56	1.66
20	0.18	0.27	0.36	0.46	0.55	0.64	0.74	0.82	0.92	1.00	1.10	1.20	1.29	1.40	1.50	1.61
30	0.11	0.21	0.30	0.39	0.48	0.57	0.66	0.77	0.86	0.95	1.05	1.15	1.25	1.36	1.48	X
40	X	0.11	0.21	0.32	0.43	0.52	0.62	0.71	0.80	0.90	1.00	1.10	1.20	1.30	X	X
50	X	X	0.12	0.22	0.32	0.45	0.55	0.64	0.74	0.83	0.93	1.03	1.14	X	X	X
60	X	X	X	0.15	0.26	0.36	0.46	0.56	0.66	0.76	0.86	0.96	X	X	X	X

ΔT1= Temperature difference hot water inlet minus outlet ΔT2= Average water temperature minus air inlet temperature

Get In Touch

Call: 0845 6880112  
Email: [info@adremit.co.uk](mailto:info@adremit.co.uk)

Our Address

Puravent, Adremit Limited, Unit 5a, Commercial Yard, Settle, North Yorkshire, BD24 9RH

# Accessories – additional sections

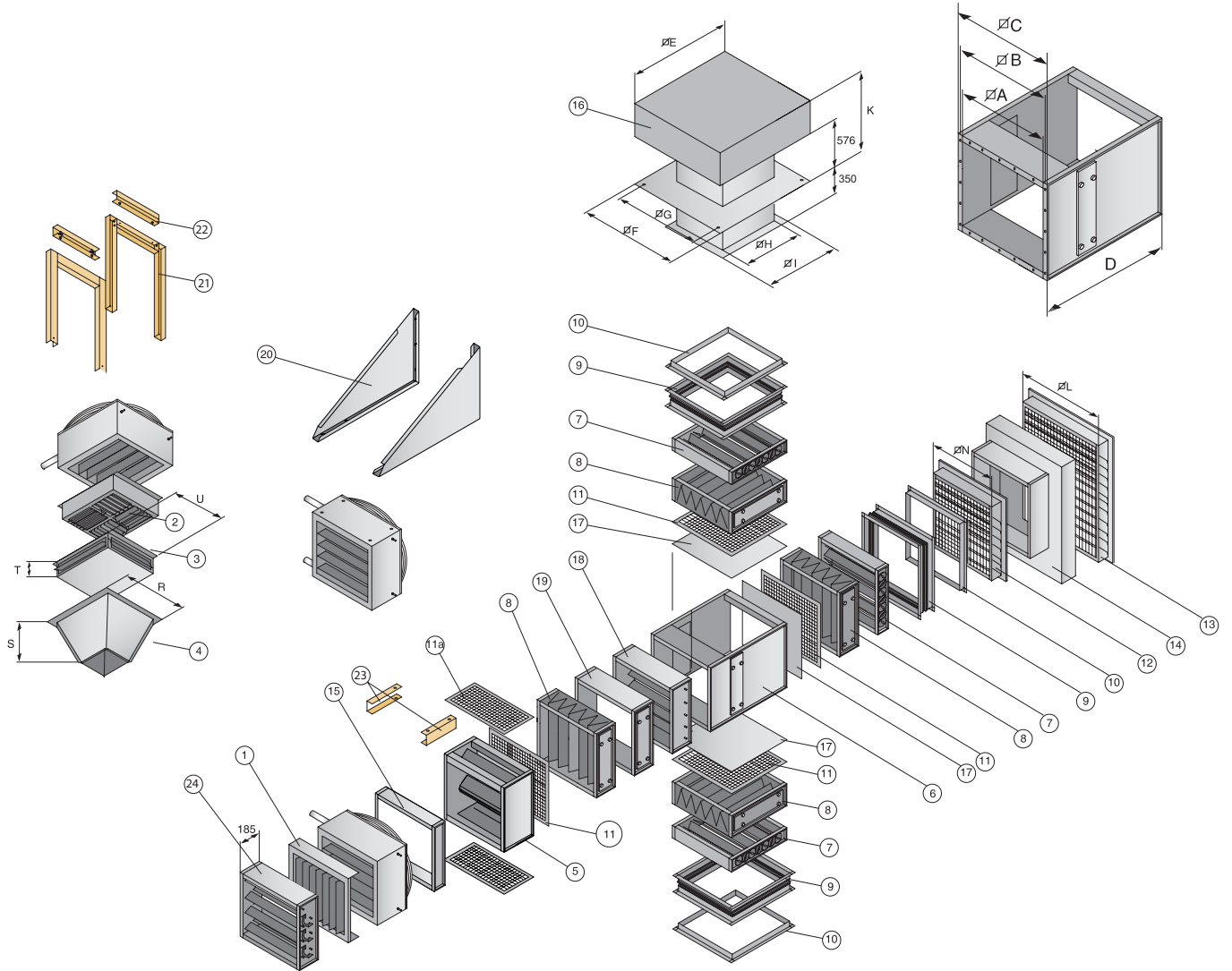

- | Position | Description                               |
|----------|---|
| 1        | Vertical louvres                          |
| 2        | Downflow hood 4-sided vertical            |
| 3        | Downflow hood 4-sided horizontal          |
| 4        | Destratification hood                     |
| 5        | Mixing box (short) incl. dampers          |
| 6        | Mixing box for dampers                    |
| 7        | Damper                                    |
| 8        | Filter box with filter (EU 3)             |
| 9        | Flexible connection                       |
| 10       | Corner profile                            |
| 11       | Mesh                                      |
| 11a      | Mesh                                      |
| 12       | Weather grill ≤ 50% fresh air intake      |
| 13       | Weather grill > 50%-100% fresh air intake |
| 14       | Transition piece for 13                   |
| 15       | Empty section 120 mm                      |
| 16       | Rain cap incl. adhesive plate (aluminium) |
| 17       | Blanking plate                            |
| 18       | Motor protection damper                   |
| 19       | Empty section 240 mm                      |
| 20       | Wall bracket                              |
| 21       | Ceiling bracket, vertical                 |
| 22       | Shock absorber set for 21                 |
| 23       | Ceiling bracket, horizontal               |
| 24       | induction damper                          |

Type	A	B	C	D	E	F	G	H
100	390	415	443	463	690	740	690	380
200	520	545	573	593	920	920	820	510
300	670	695	723	743	1180	1240	975	665
400	800	835	853	873	1420	1240	1110	800

Type	I	K	L	N	R	S	T	U
100	440	800	516	386	439	212	120	406
200	570	895	666	516	573	253	151	530
300	720	940	796	666	724	300	175	680
400	860	1075	1005	796	853	329	220	815

Hot water-supplied air heaters - 46

## Get In Touch

Call: 0845 6880112  
 Email: [info@adremit.co.uk](mailto:info@adremit.co.uk)

## Our Address

Puravent, Adremit Limited, Unit 5a, Commercial Yard, Settle, North Yorkshire, BD24 9RH



# Assembly/location suggestions

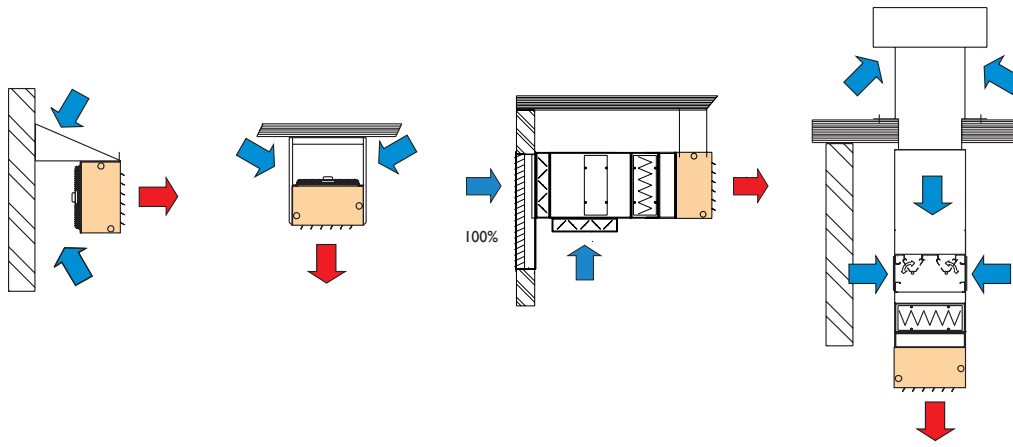

Tanner MDA maximum assembly height for

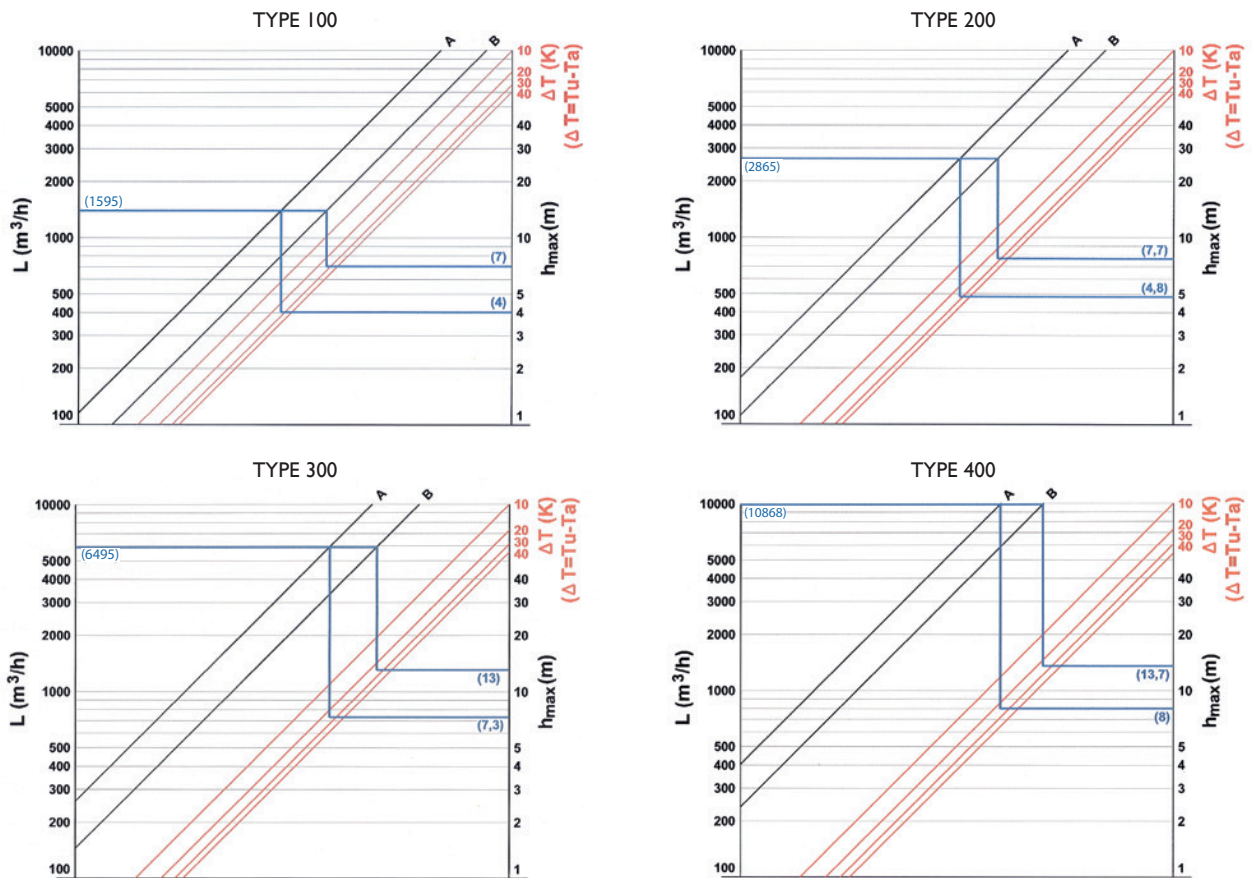

**Calculation example:** Tanner MDA 123L (Type 100)

- The table indicates that the air displacement with this unit is:  $L = 1595 \text{ m}^3/\text{h}$
- If the intake temperature ( $T_a$ ) is  $15^\circ\text{C}$ , the table shows that the outlet temperature ( $T_u$ ) will be  $42.8^\circ\text{C}$ . The temperature difference is:  
 $Dt = T_u - T_a$   
 $Dt = 42.8 - 15$   
 $Dt = 27.8\text{K}$

- The table (TYPE 100) indicates that:
  - A** or the basic model, without accessories, the max. suspension height is: = 4m
  - B** or the combination with a destratification hood, the max. suspension height is: = 7m

**Get In Touch**

Call: 0845 6880112  
 Email: [info@adremit.co.uk](mailto:info@adremit.co.uk)

**Our Address**

Puravent, Adremit Limited, Unit 5a, Commercial Yard, Settle, North Yorkshire, BD24 9RH

AC Motor

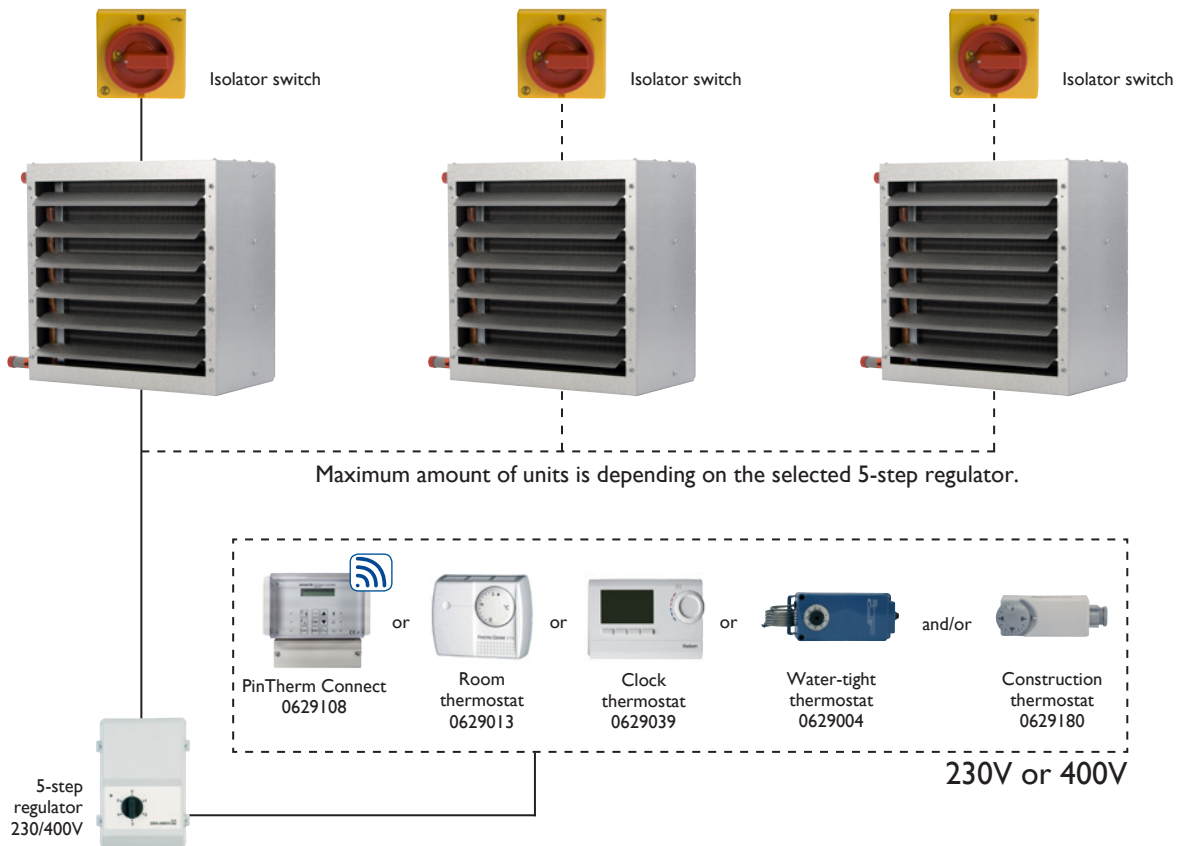
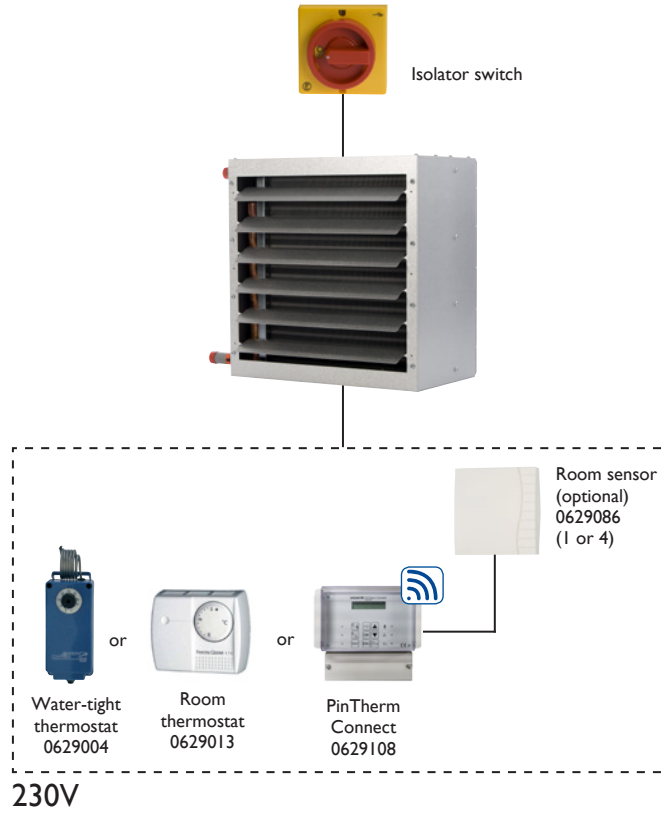

Hot water-supplied air heaters - 48

Get In Touch

Call: 0845 6880112  
 Email: [info@adremit.co.uk](mailto:info@adremit.co.uk)



Our Address

Puravent, Adremit Limited, Unit 5a, Commercial Yard, Settle, North Yorkshire, BD24 9RH

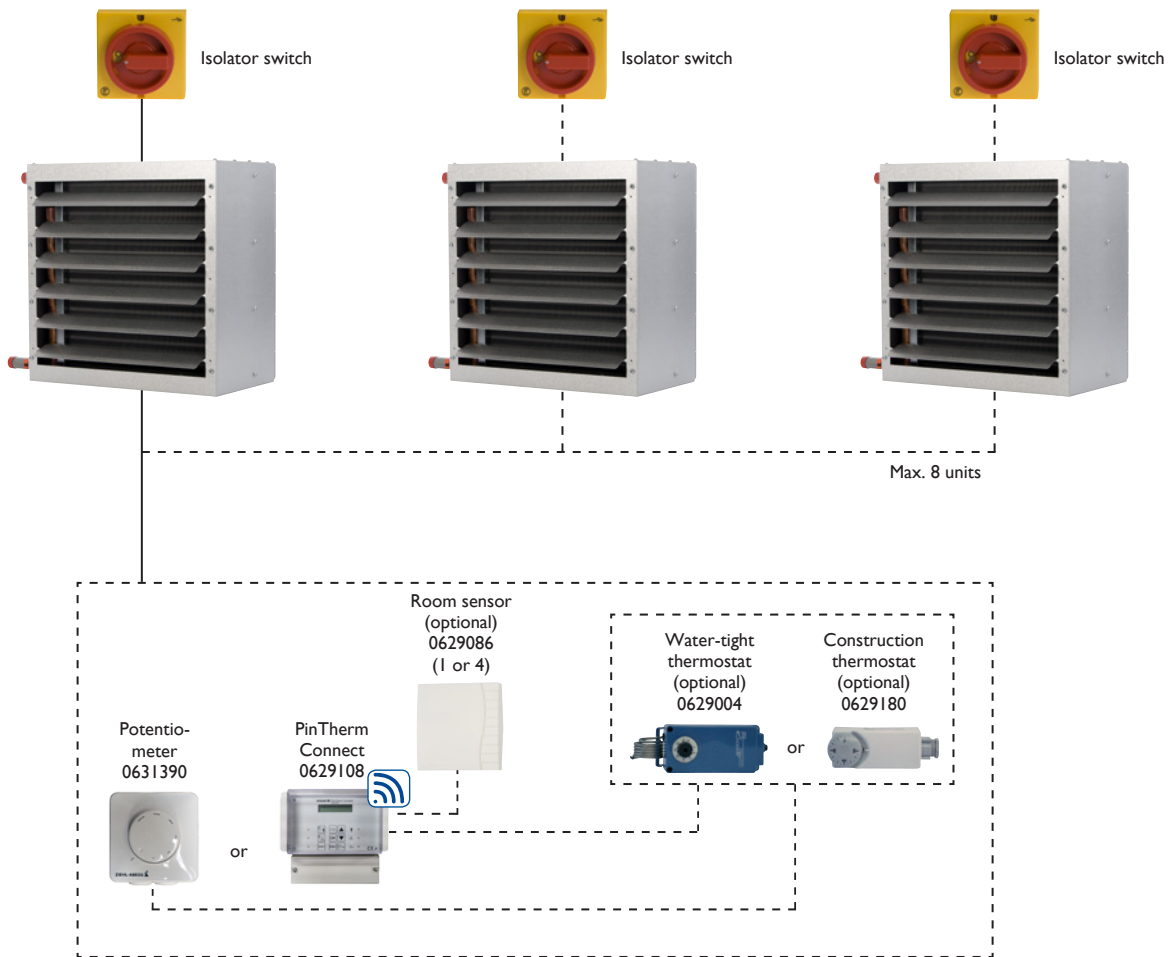
## EC Motor



### Get In Touch

 Call: [0845 6880112](tel:08456880112)  
 Email: [info@adremit.co.uk](mailto:info@adremit.co.uk)

### Our Address

Puravent, Adremit Limited, Unit 5a, Commercial Yard,  
Settle, North Yorkshire, BD24 9RH