



# RTRD 7 SPEED CONTROL SYSTEMAIR

Item no. 5943

Document type: **Product card**  
 Document date: **2019-06-24**  
 Generated by: **Systemair Online Catalogue**

## Description

Manual five-step transformer (with motor protection)

A three-phase transformer which controls the fan speed by altering the supply voltage in five fixed steps. The steps are adjusted manually, using the control knob on the front of the unit.

An integral motor protection device is included which cuts the supply voltage to the fan if the thermal contact in the fan motor is activated. The unit is reset by turning the knob to "0" for 10 seconds, after which the unit restarts.

Input terminals for room thermostat RT and frost protection thermostat FS cut supply voltage to the fan when the circuit is broken. When the frost protection thermostat FS breaks the circuit, it is reset in the same way as when the TK is triggered. Terminals are linked before delivery. The indicator lamp on the front shows that the transformer is in operation.

The transformer has 230V terminals for operating dampers, electric heater batteries or other external equipment. These terminals have no current when the transformer knob is in position 0, or when the TK or RT input is open. Supply voltage: 400V 50/60Hz.



## Technical parameters

Classification	
Product type	Speed controls, transformers
Default group	
Voltage	400 V
Phase	3 ~
Frequency	50/60 Hz
Current	7 A
Enclosure class	IP21
Max. power dissipation	110 W
Dimension	
Width	270 mm
Depth	172 mm
Height	323 mm
Weight	15,5 kg

### Get In Touch

Call: [0845 6880112](tel:08456880112)  
 Email: [info@adremit.co.uk](mailto:info@adremit.co.uk)

### Our Address

Puravent, Adremit Limited, Unit 5a, Commercial Yard, Settle, North Yorkshire, BD24 9RH



## Wiring

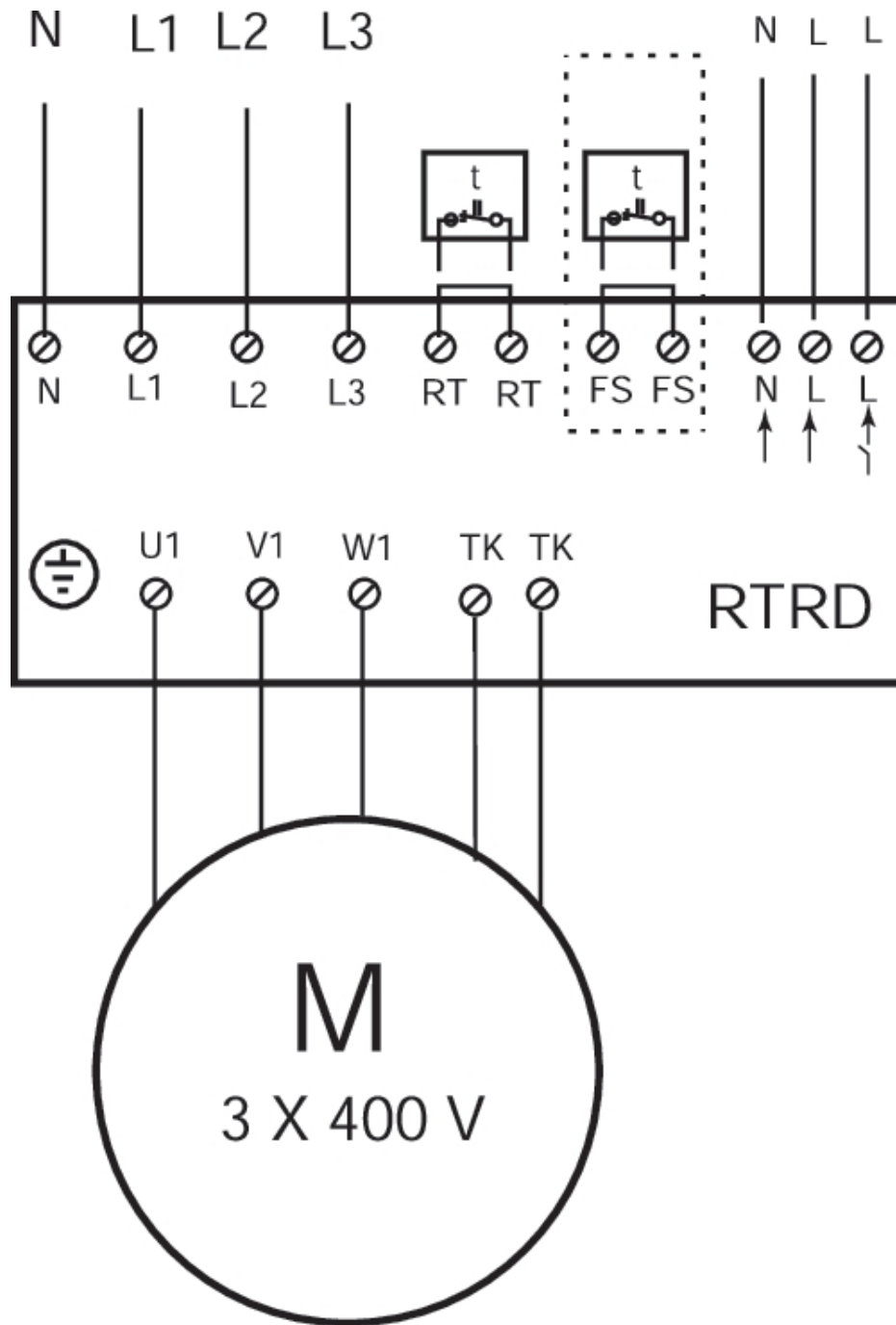

### Accessories

### Documentation

 IMO RTRD, RTRDU\_DE\_GB\_FR\_SE.pdf (573,35kB)

 EU\_declaration\_of\_conformity\_CXE\_AVC Modbus, PXDM, RTRD\_RTRDU, RETP, REPT.pdf (35,45kB)

### Specification text

Name: **RTRD 7 SPEED CONTROL SYSTEM**AIR | Item no.: **5943**

Document type: **Product card** | Document date: **2019-06-24** | Generated by: **Online catalogue**

2 / 2

### Get In Touch

 Call: [0845 6880112](tel:08456880112)  
 Email: [info@adremit.co.uk](mailto:info@adremit.co.uk)

### Our Address

Puravent, Adremit Limited, Unit 5a, Commercial Yard,  
Settle, North Yorkshire, BD24 9RH