



# RS 100-50 L3 SILEO

Item no. 39635

Version: 400V 3~



## Description

- Speed-controllable
- Integral thermal contacts
- Can be installed in any position
- Maintenance-free and reliable

The RS models have impellers with backward-curved blades and external rotor motors. The motor and impeller are mounted on the access cover to facilitate easy maintenance. To protect the motor from overheating the RS has integral thermal contacts with external leads for connection to a motor protection device. The fan can be installed in any position and is easy to connect using the DS flexible connections. The casing is manufactured from galvanised sheet steel.



## Technical parameters

Nominal data	
Voltage	400 V
Frequency	50 Hz
Phase	3 ~
Input power (P1)	2210 W
Current	4,27 A
Max. airflow	3,06 m³/s
R.p.m.	1368 r.p.m.
Weight	83 kg
Temperature data	
Max. temperature of transported air	70 °C
Max. temperature of transported air when speed-controlled	70 °C
Sound data	
Sound pressure level at 3 m	64,2 dB(A)

### Get In Touch

Call: [0845 6880112](tel:08456880112)  
 Email: [info@adremit.co.uk](mailto:info@adremit.co.uk)

### Our Address

Puravent, Adremit Limited, Unit 5a, Commercial Yard,  
 Settle, North Yorkshire, BD24 9RH



### Protection / Classification

Insulation class	F
Enclosure class, motor	IP54

### ErP

ErP ready	ErP 2018
-----------	----------

## Diagrams

### Diagrams

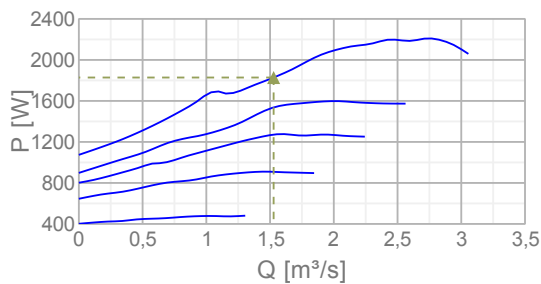
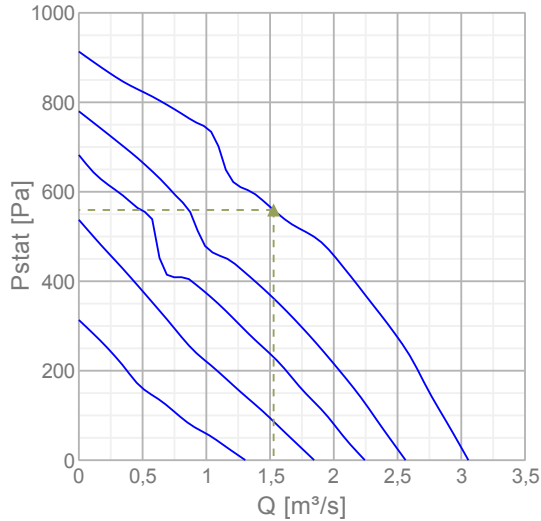

### Max efficiency

Hydraulic data										
▲ Working air flow										1,53 m³/s
▲ Working static pressure										559 Pa
▲ Power										1828 W
Speed										1390 r.p.m.
Current										3,76 A
SFP										1,2 W/(l/s)
Voltage										400 V
Sound power level		63	125	250	500	1k	2k	4k	8k	Tot
Inlet	dB(A)	69	78	75	79	77	74	70	64	84
Outlet	dB(A)	72	81	82	83	84	79	73	64	90
Surrounding	dB(A)	58	70	63	62	60	56	52	49	72

Name: **RS 100-50 L3 SILEO** | Item no.: **39635** | Version: **400V 3~**

Document type: **Product card** | Document date: **2019-06-25** | Generated by: **Online catalogue**

2 / 5

### Get In Touch

Call: [0845 6880112](tel:08456880112)  
 Email: [info@adremit.co.uk](mailto:info@adremit.co.uk)

### Our Address

Puravent, Adremit Limited, Unit 5a, Commercial Yard,  
 Settle, North Yorkshire, BD24 9RH

## Dimensions

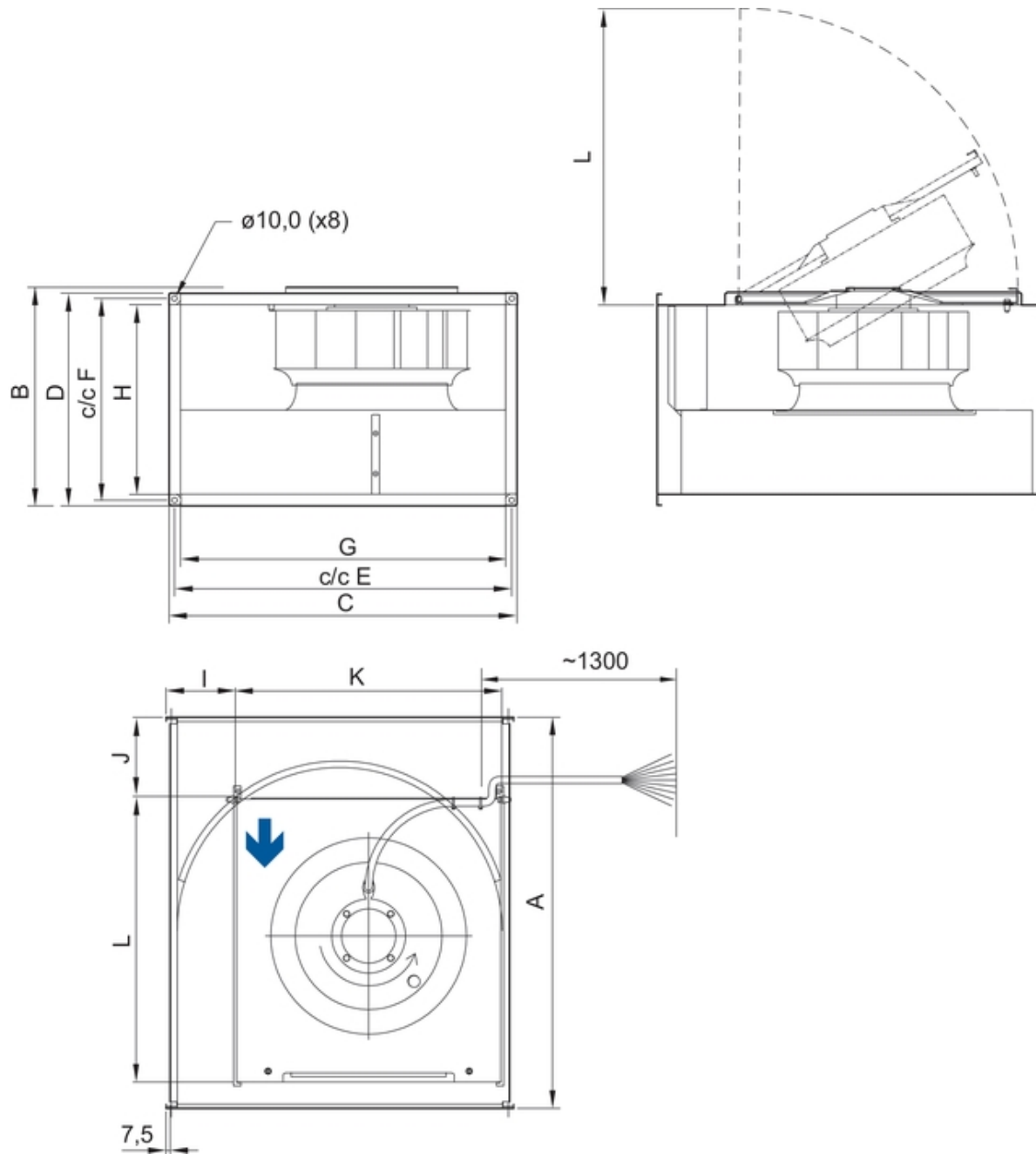



RS	A	B	C	D	E	F	G	H	I	J	K	L
100-50 L	982	583	1040	541	1020	520	998	498	298,5	290	614	644

Name: **RS 100-50 L3 SILEO** | Item no.: **39635** | Version: **400V 3~**

Document type: **Product card** | Document date: **2019-06-25** | Generated by: **Online catalogue**

3 / 5

### Get In Touch

 Call: [0845 6880112](tel:08456880112)  
 Email: [info@adremit.co.uk](mailto:info@adremit.co.uk)

### Our Address

Puravent, Adremit Limited, Unit 5a, Commercial Yard,  
Settle, North Yorkshire, BD24 9RH

400V 3~

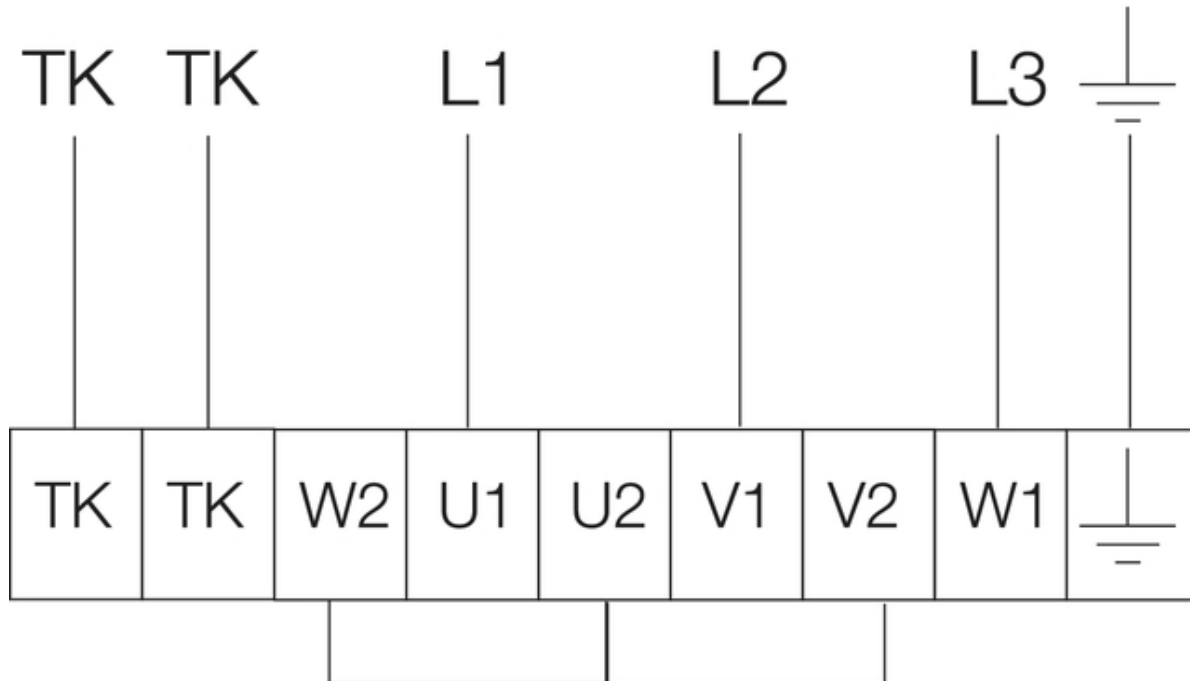

### Accessories

#### Electric accessories

[RTRD 7 speed control Systemair \(5943\)](#)  
[RTRDU 7 Speed contr. Systemair \(5947\)](#)  
[RT 0-30 Room Thermostat \(5151\)](#)  
[STDT 16 Motor Protection \(5152\)](#)  
[STDT 16E Motor Protection \(5153\)](#)  
[CO2RT-R-D Transmitter \(6993\)](#)  
[Presence detector/IR24-P \(6995\)](#)  
[DTV200 \(6261\)](#)  
[REV-5POL/07 ON/OFF \(33980\)](#)  
[DTV500A \(96807\)](#)

#### Accessories

[PGK 100-50-3-2,0 Duct cooler \(6601\)](#)  
[VBR 100-50-2 Water heating bat \(5470\)](#)  
[VBR 100-50-3 Water heating bat \(5478\)](#)  
[LDR 100-50 Silencer \(5067\)](#)  
[FFK 100-50 filter cassette \(30237\)](#)  
[DS 100-50 Flexible connection \(1555\)](#)  
[DXRE 100-50-3-2,5 Duct cooler \(7959\)](#)  
[RB 100-50/45-3 400V/3 Duct hea \(9649\)](#)  
[RB 100-50/68-4 400V/3 Duct hea \(9650\)](#)  
[RB 100-50/80-5 400V/3 Duct hea \(9661\)](#)  
[RKT-SYS-1000x500-S \(43641\)](#)  
[RK-SYS-1000x500-R \(43650\)](#)  
[RK-SYS-1000x500-S \(43659\)](#)

### Documentation

 [202341\\_Fans\\_Instructions\\_CE\\_A010.pdf \(1,83MB\)](#)

### Get In Touch

 **Call:** [0845 6880112](tel:08456880112)  
 **Email:** [info@adremite.co.uk](mailto:info@adremite.co.uk)

### Our Address

Puravent, Adremite Limited, Unit 5a, Commercial Yard,  
 Settle, North Yorkshire, BD24 9RH



## Specification text

The box consists of electroplated steel plate. The fans have a radial impeller with backwards- curved impeller vanes witch are pivoting. For making cleaning and attendance easier the fan device is assembled at the folding closure head. The fans can be installed in each fitting position and with the help of the flexible DS connection they are very easy to built in. The actuation is carried out by a foolproofed, maintenance- free and speed- controlled external rotor motor. For protecting the motor, the production run has built in thermal contacts with manually reset device with completed lines to a motor protection device according to EN 60335-2-80. For annealing the engine is designed inside the air flow. Impeller according to VDI 2060, quality category Q6,3 and dynamically weigh heavy in two levels.

### Get In Touch



Call: [0845 6880112](tel:08456880112)



Email: [info@adremit.co.uk](mailto:info@adremit.co.uk)

### Our Address

Puravent, Adremit Limited, Unit 5a, Commercial Yard,  
Settle, North Yorkshire, BD24 9RH