



APPLICATIONS

The recessed over door heater is designed for use above frequently opened doors to limit the loss of heated air and the ingress of cold air. Typical installations include shops, entrance halls, and workshop/warehouse doors.

The purpose designed mounting arrangement allows the recessed over door heater to be fitted within the ceiling space or over door bulkhead provided adequate provision is made for the incoming airflow.

FEATURES

- 3kW, 4.5kW, 6kW and 9kW units available
- Special in-ceiling or bulkhead mounting
- Over temperature cut-out with power off reset
- Can be mounted from above or below ceiling
- Complete with grille frame for a neat installation
- Selection of heat and fan only with remote switch unit
- Outlet grille and frame have white powder coated finish

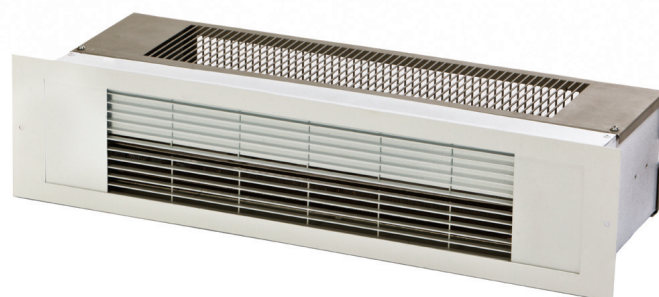

CONTROL

Heat output and fan only control is achieved with the remote switch unit.

RDH-3000 - fan only with 1kW, 2kW and 3kW.

RDH-4500 - fan only with 2.25kW and 4.5kW.

RDH-6000 - fan only with 3kW and 6kW.

RDH-9000 - fan only with 4.5kW and 9kW.

The RDH-3000 and RDH-4500 can be controlled by remote thermostat and/or time controller of suitable rating, connected in the main supply line.

The RDH-6000 and RDH-9000 can be controlled by remote thermostat and/or time controller of suitable rating, in the heater control circuit.,

Get In Touch

Call: [0845 6880112](tel:08456880112)
Email: info@adremit.co.uk

Our Address

Puravent, Adremit Limited, Unit 5a, Commercial Yard,
Settle, North Yorkshire, BD24 9RH

INSTALLATION

The heaters are designed to take their input air from the ceiling void. It is therefore imperative that a suitably sized inlet grille is provided within the ceiling or enclosure. The minimum clearance to the top inlet grille is 20mm, to the back 30mm and to the front inlet grille 100mm. If one inlet grille is at its minimum dimension the other must have an unrestricted airflow.

For optimum effect the heater should be mounted as close as possible to the top of the doorway. The maximum recommended mounting height is 2.3m for 3kW and 2.8m for 4.5kW, 6kW and 9kW units.

It is recommended a frame is provided around the ceiling opening. The adjustable brackets then allow fixing to the top of this frame or to the face of the ceiling. Alternatively, holes are provided in the top of heater for drop rod fixings.

The grille frame is fixed directly to the ceiling to provide a decorative finish.

3kW, 4.5kW and 6kW units are only suitable for connection to a 230V single phase power supply. The 9kW is suitable for both a 230V single phase or 400V three phase and neutral supply

Connection should be made to a suitably fused power supply via the remote switch unit. 4.5kW, 6kW and 9kW must be connected directly to the power distribution board. Connection should be via a 2 pole switched connection unit having a contact separation of at least 3mm in all poles.

All electrical connections should be made by a suitably qualified person in accordance with the latest edition of the IEE Requirements for Electrical Installation (BS 7671:2008).

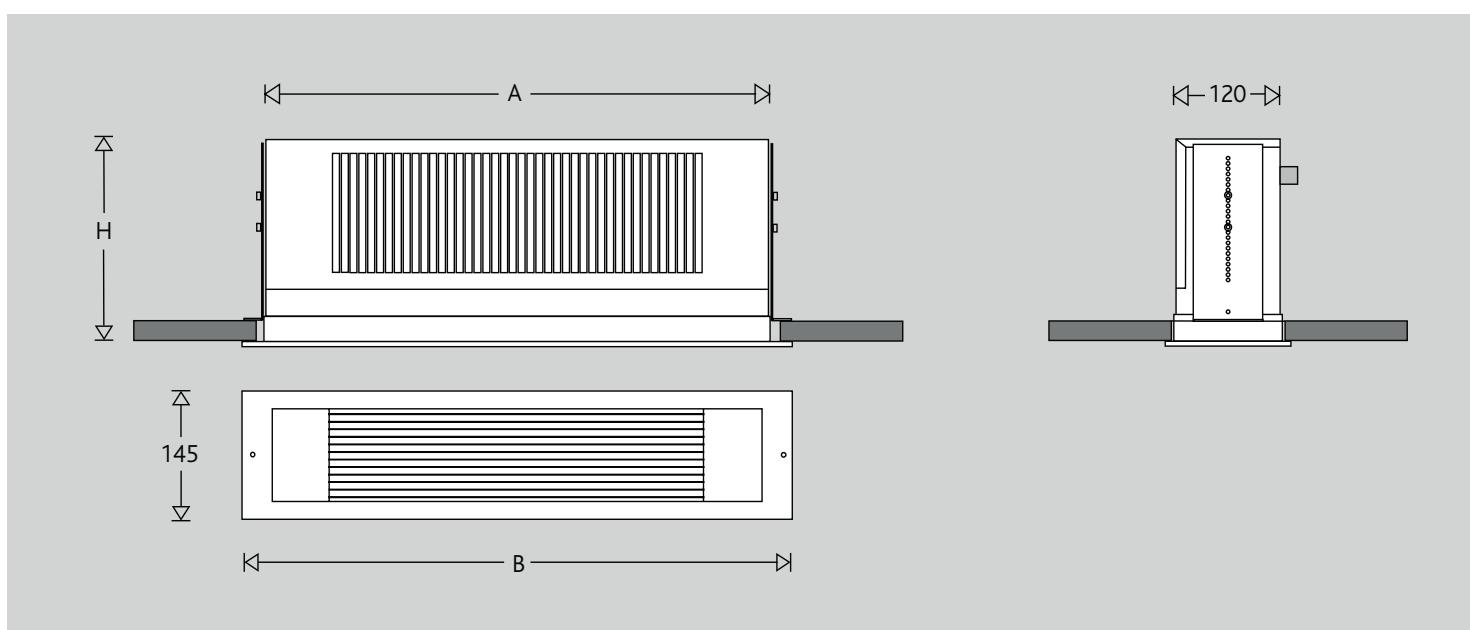

CAT No.		Watts	Volts	Heater			Grille			Weight kgs
				Length (A) mm	Height (H) mm	Depth mm	Length (B) mm	Height mm	Depth mm	
RDH-3000	Remote switch included	3000	230	570	210	120	625	145	30	6.0
RDH-4500	Remote switch included	4500	230	570	210	120	625	145	30	6.0
RDH-6000	Remote switch included	6000	230	800	210	120	855	145	30	13.0
RDH-9000	Remote switch included	9000	400	1170	210	120	1225	145	30	16.0

Get In Touch

Call: [0845 6880112](tel:08456880112)
 Email: info@adremit.co.uk

Our Address

Puravent, Adremit Limited, Unit 5a, Commercial Yard, Settle, North Yorkshire, BD24 9RH