



**REGISTER
YOUR WARRANTY
ONLINE AT
www.sanuvorex.com**

QUATTRO AIR DISINFECTION SYSTEM Commercial Model



IMPORTANT SAFETY INSTRUCTIONS

READ AND SAVE THESE SAFETY INSTRUCTIONS BEFORE USING THIS PRODUCT.



Read and follow all instructions contained in the manual before using the product. Read the maintenance instructions before opening the UV unit or system. Failure to comply with these instructions may result in injuries or damage to the UV unit or system.

⚠ NEVER EXPOSE EYES OR SKIN TO AN OPERATING UV LAMP. ⚠

- Installation and servicing** of UV units or systems (in an air conditioning system or not) **can be hazardous. Only trained and qualified service personnel** should install, repair or service equipment.
- Untrained personnel** can perform **basic maintenance** functions such as replacing lamp(s) and/or filter(s). All other operations should be performed by trained service personnel.
- The unit is not to be used by persons (including children) with reduced physical, sensory or mental capabilities, or lack of experience and knowledge.
⚠ CAUTION: Unit is not a toy. Keep away from unsupervised children. Do not leave children unattended with the unit.
- DO NOT hang onto the UV unit or system.**
- Some UV units or systems could be heavy: Make sure you have a minimum of 2 people to safely move or install these UV units or systems, and make sure you adopt the most ergonomic position possible (use UV unit or system handles, if applicable).
⚠ CAUTION: Installing or maintaining heavy equipment, especially overhead, can cause back pain or other injuries.
- When installing or servicing an overhead UV unit or system, be careful not to fall off the stepladder. Furthermore, make sure the UV unit or system latches are always in place to prevent falling parts.
⚠ CAUTION: Some parts of some UV units and systems may open suddenly if the UV unit or system is installed high up without its locks.
- Units that are obviously damaged must not be operated.
- ⚠ CAUTION:** When working on the UV unit or system, observe precautions on the literature, tags and labels attached to the UV unit or system, and all other safety precautions considered as best practices in the HVAC industry, if applicable.
- When applicable, local regulation may comprise more restrictive installation and/or certification requirements. The aforementioned requirements prevail on those of this document and the installer agree to conform to these at his own expense.
- Follow all the safety instructions outlined in this document and respect all local and national codes applicable.
- All UV units or systems contain a UV-C source. Damage to the housing or unintended use of the UV unit or system may result in harmful UV-C leaks. UV-C may, even in little doses, cause harm to the eyes and skin.
- Never expose eyes or skin to an operating UV lamp.** Therefore, **before installing or performing maintenance** on the UV unit or system, **TURN OFF AND DISCONNECT** the UV unit or system **from all power sources** (there may be more than one switch to disconnect) and also disconnect the HVAC system, if applicable.
⚠ CAUTION: Electrical shock may cause injuries or possibly death. **FIRST AID INSTRUCTIONS:** If injured, consult a doctor.
- UV rays may damage certain types of filters (polymer or plastic); please keep the UV unit or system light away from shining directly on plastic.
- When installing or performing maintenance on the UV unit or system, it is recommended to **wear safety gloves**. In order to avoid reduced performance of lamp(s), **do not touch lamp glass without gloves**.
- Just like conventional fluorescent lamps, UV lamps contain a small quantity of mercury: if a lamp breaks, clean and **dispose of with care**. UV lamps can be disposed/recycled after use in the same way as any other fluorescent lamps. Contact and follow the specific instructions of your local and national authorities.
- Use only specified SANUVOX branded replacement UV lamps for your UV unit or system.** Use of any other lamps will void your warranty and can result in damage to the UV unit or system.
- Sanuvorex UV units or systems are not waterproof. **DO NOT INSTALL OUTDOORS OR IN WET LOCATION** unless specified otherwise.
- The use of a UV unit or system is a supplement to and not a substitute for standard infection control practices; users must continue to follow all current infection control practices, including those related to the cleaning and disinfection of environmental surfaces.

SAVE THESE INSTRUCTIONS

For any inquiries on a UV unit or system, contact:

Robert Smith
146 Barr St, Saint-Laurent
Quebec, CA, H4T 1Y4
1-888-726-8869
techsupport@sanuvorex.com

Installation Date: _____ Installed by: _____

Installer Contact Info.: _____

Sanuvorex Technologies Inc, © 2019 All rights reserved. November 2022 EN v.2.2

Get In Touch

Call: 0845 6880112
 Email: info@adremit.co.uk

Our Address



Puravent, Adremit Limited, Unit 5a, Commercial Yard,
Settle, North Yorkshire, BD24 9RH



TABLE OF CONTENTS

△ IMPORTANT SAFETY INSTRUCTIONS △	1
TABLE OF CONTENTS	2
ABOUT THE PRODUCT	3
COMPONENTS	3
How it Works	3
ACCESSORIES & KITS	3
SETUP & INSTALLATION	4
What you will need	4
What's included	4
Setup	4
Step by Step Installation	4
OPERATION	7
How to Operate your Product	7
How to Read the LED Signal	7
MAINTENANCE	8
How to Replace Lamp(s)	8
Step by Step Lamp Replacement	8
How to Clean your Product	10
STORAGE	10
ULTRAVIOLETS: UVC	10
ELECTRICAL RATINGS, POWER CONSUMPTION & AVAILABLE VOLTAGE	10
TROUBLESHOOTING	11
What you will need	11
Problems & Solutions Table	11
A. Step by Step Lamp Test	11
WARRANTY	12
CUSTOMER SERVICE	12

Get In Touch

 **Call:** 0845 6880112
 **Email:** info@adremit.co.uk

Our Address

Puravent, Adremit Limited, Unit 5a, Commercial Yard,
Settle, North Yorkshire, BD24 9RH





ABOUT THE PRODUCT

Congratulations on the purchase and installation of your new Sanuvox ultraviolet air purifier. Sanuvox UV air purifiers are the most advanced air purification systems available having been proven to help reduce up to 99.99% of biological and chemical contaminants that circulate throughout your home or facility. Sanuvox systems have been tested by medical universities and Independent 3rd party laboratories.

The Sanuvox Quattro system is designed for the disinfection of airborne mold, virus, bacteria and common odors up to a 5-ton HVAC system.

The Sanuvox QUATTRO is installed in the RETURN (preferred) or SUPPLY plenum of the HVAC equipment treating 100% of the the air-stream. The actual percentage is based on the duct size, percentage of fresh air, velocity and the specific contaminants to be treated. Depending on the variables above, more than one QUATTRO may be required for commercial applications.

For information or recommendations on how to size your specific application, please call SANUVOX at 1-888-726-8869.

COMPONENTS

How it Works

The Quattro is installed in a return or supply duct parallel to air flow for maximum exposure time and consists of four 18" lamps, each with their own parabolic aluminum reflector.

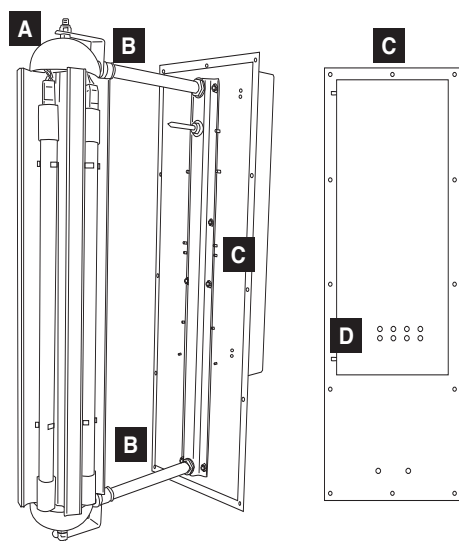

- A. UV Lamp Assembly
- B. Arm's Adjustable Clutches
- C. Black Front Plate
- D. LED Signals

ACCESSORIES & KITS

The following optional accessories and/or kits work great with your product (sold separately).

½ EMT Fitting

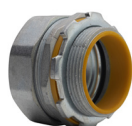

Fitting for connections.

For instruction manuals or information about your optional accessories and/or kits, please call SANUVOX at 1-888-726-8869 or visit www.sanuvox.com.

Get In Touch

 **Call:** 0845 6880112
 **Email:** info@adremit.co.uk

Our Address

Puravent, Adremit Limited, Unit 5a, Commercial Yard,
Settle, North Yorkshire, BD24 9RH





SETUP & INSTALLATION

What you will need

A utility knife to unpack all components, a drill, a pair of scissors or a saw, a Phillips #2 screwdriver, a 11/32 nutdriver and a 1/4 nutdriver.

⚠ CAUTION: Handle your product with care to avoid breaking parts. Make sure you have a free and safe space to unpack, install and setup your product. Confirm you have access to the necessary power source for the product requirements (see unit or system label). If you have any questions regarding the installation instructions, call SANUVOX at 1-888-726-8869.

What's included

The QUATTRO with its UV lamps (4) and a basic installation kit.

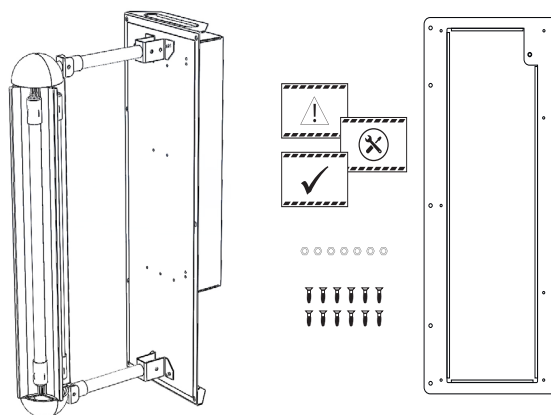

The installation kit includes: a UV caution decal, a maintenance decal, a warranty card, nuts for frame (7), a frame and self tapping screws (12).

Setup

The recommended ideal location for the installation of the purifier is the main return duct, just before the filters and the air conditioning coil. If there is a humidifier installed in the ductwork, make sure that the purifier is installed before the humidifier and that the humidifier is protected from UV rays. Should it prove impossible to install the purifier in the return line, the main supply line is still a suitable choice. The black control panel should be on the outside of the duct.

⚠ CAUTION: Make sure the site can be supplied with the necessary power requirements. Ensure that there is adequate clearance for service and maintenance.

Step by Step Installation



1. **Turn off all power to the HVAC equipment and prepare the QUATTRO for installation.** Remove it from its packaging.

NOTE: To prevent damage, carefully remove the frame from the box first. The lamps are installed in the unit at the factory. Use caution as all lamps are fragile.

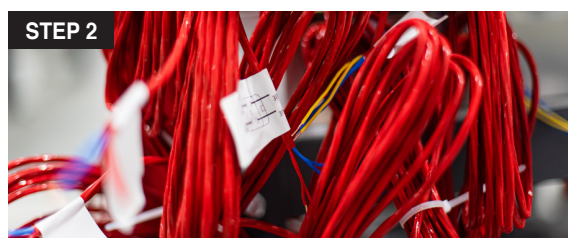

2. Ultraviolet light may damage plastic or exposed wiring (Sanuvox wire set is teflon coated which is resistant to UV exposure).

If any plastic or wiring is exposed to direct UV exposure, **wrap exposed material(s) with aluminum tape or metal conduit.**

Get In Touch

Call: 0845 6880112
 Email: info@adremit.co.uk

Our Address

Puravent, Adremit Limited, Unit 5a, Commercial Yard,
Settle, North Yorkshire, BD24 9RH

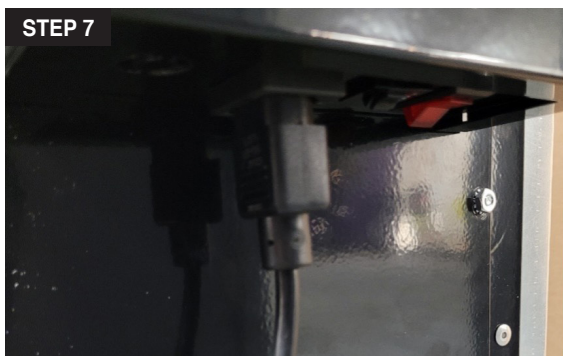
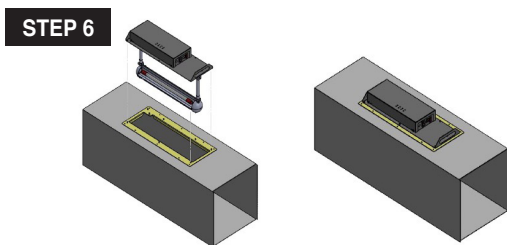
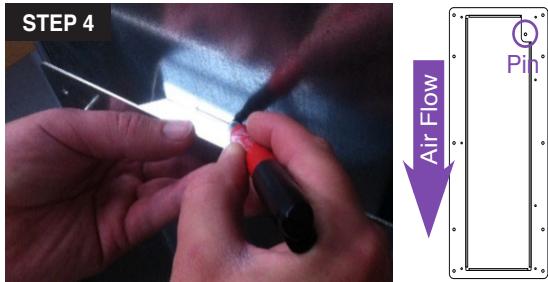
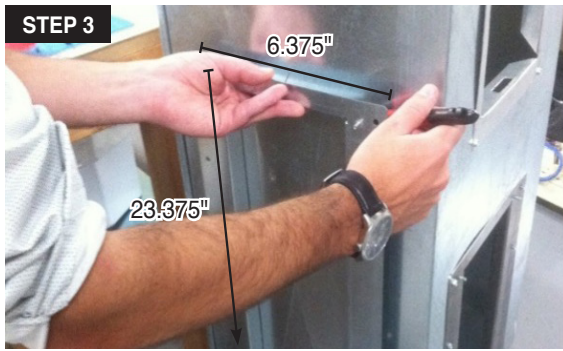

3. Use the frame as a template to cut a rectangular hole in the duct where the unit will be installed. The duct opening window should have the following dimensions: approximately 23.375" x 6.375".

4. Screw the frame to the duct using the 12 provided self-tapping screws.

NOTE: The frame has an activation pin on the top right corner; position it upwind of the air flow.

5. **Adjust the UV lamp assembly so it will be positioned in the middle of the duct.** The arms that support the lamp assembly have an adjustable clutch which allows the lamp and extrusion to be set at a distance from 10" to 15" from the backplate

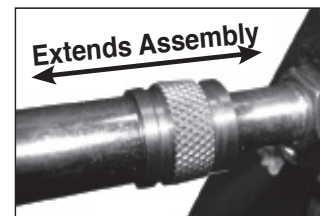

To adjust the assembly, loosen the clutch by turning it counter-clockwise. Rotate the clutch clockwise to tighten. The lamps and extrusion can then be positioned to the desired distance from the backplate.

6. **Insert the unit through the frame and secure it using the 7 provided nuts**, so that the top right of the unit is aligned with the activation pin of the frame. Tilt the unit as needed during insertion to fit the cutout.

NOTE: For easier installation pierce through the sealing foam on the 7 installation holes.

7. Connect the C13 power cable to its receptacle, then connect the power cord to a power outlet.

NOTE: Make sure that the unit's switch is in the OFF position and the power cable is unpowered during the wiring.

You are now ready to enjoy superior indoor air quality.

Get In Touch



Call: 0845 6880112
Email: info@adremit.co.uk

Our Address

Puravent, Adremit Limited, Unit 5a, Commercial Yard, Settle, North Yorkshire, BD24 9RH



Get In Touch

 **Call:** [0845 6880112](tel:08456880112)
 **Email:** info@adremit.co.uk

Our Address

Puravent, Adremit Limited, Unit 5a, Commercial Yard,
Settle, North Yorkshire, BD24 9RH





OPERATION

How to Operate your Product

The QUATTRO has an ON-OFF toggle switch and a circuit breaker located at the bottom of the front cover. The QUATTRO is an automatic unit: once it's installed and plugged in, simply press the power switch to turn it ON and enjoy clean air inside!

⚠ CAUTION: The suggested operating temperature range is 4 to 66°C (40 to 150°F). Operating the QUATTRO outside this range will result in decreased performance. For optimal performance, air temperature moving through the unit should be in the range of 15 to 20°C (60 to 70°F).

How to Read LED Signal

ON-OFF Toggle Switch Light

- LIGHT OFF: Unit is OFF.
- RED, LIGHT ON: Unit is ON / there is power.

When operating, the LED lights on the front cover will be lit: There are two LED lights corresponding to each of the 4 UV Lamps. The AMBER LED lights indicate the UV lamps are functioning. The RED LED lights indicate the ballast are ON.

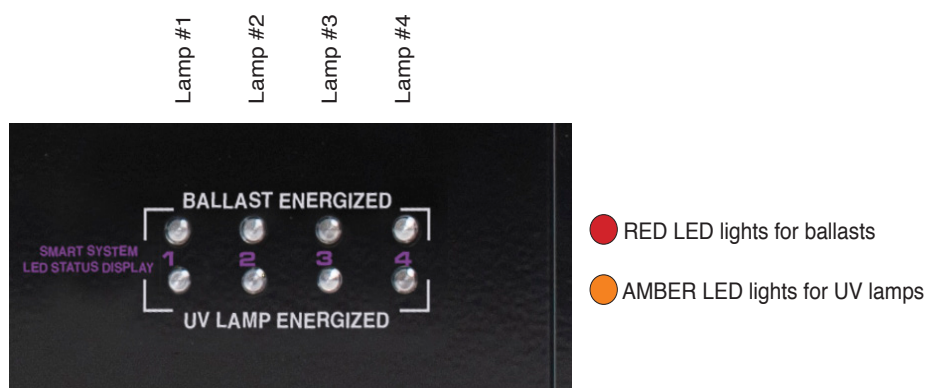

If a UV lamp is defective, its ballast RED LED light will remain ON, but its lamp AMBER LED light will be off.

If both LED lights are OFF, the ballast is not functioning.

Get In Touch

- Call: 0845 6880112
- Email: info@adremit.co.uk

Our Address

Puravent, Adremit Limited, Unit 5a, Commercial Yard, Settle, North Yorkshire, BD24 9RH



MAINTENANCE

How to Replace Lamp(s)

Lamps need periodic replacement to maintain design specifications: replace lamps after 2 years of operation. Replacing lamp on the QUATTRO is quick and easy. Simply turn off the power source, remove and dispose of old lamp, replace with new Sanuvox branded UV lamp, turn power source back on. See below for detailed step by step instructions.

⚠ CAUTION: In order to avoid reduced performance of lamp(s), do not touch lamp glass without gloves.

Step by Step Lamp Replacement



1. **Deactivate the unit.** De-energize the unit by turning off its power source.

⚠ CAUTION: Disconnect all power before performing any maintenance or service.

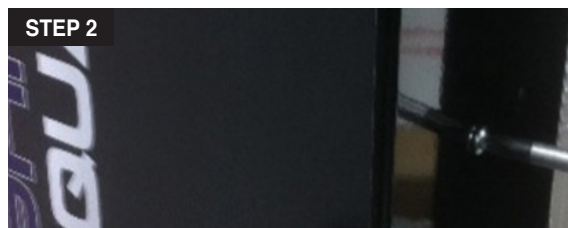

2. **Unscrew the locking screw and open the cover.**

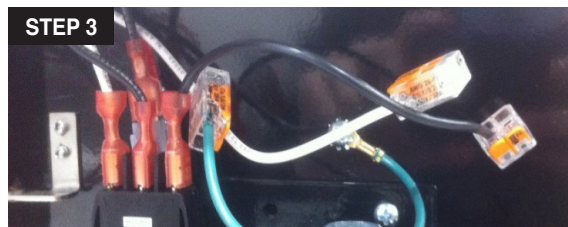

3. **Remove the building's power wires** from the three orange connectors. Refer to installation step 10.



4. **Remove the armored cable from the EMT fitting.**

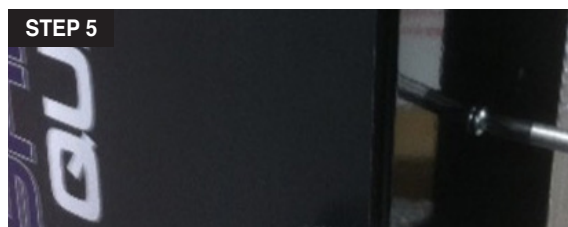

5. **Close the cover and screw the locking screw.**



6. **Unscrew the 6 retaining nuts and carefully remove the unit from its mounting frame.**

Get In Touch

 **Call:** 0845 6880112
 **Email:** info@adremit.co.uk

Our Address

Puravent, Adremit Limited, Unit 5a, Commercial Yard,
 Settle, North Yorkshire, BD24 9RH



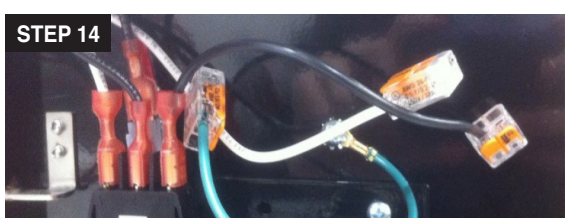
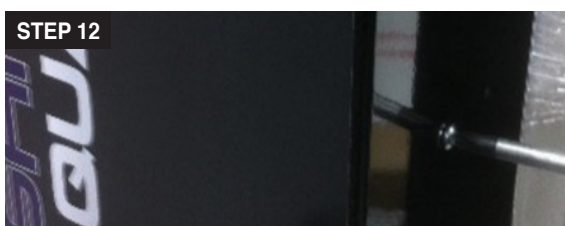

7. Once the Quattro is removed from the duct, **remove the lamp from the reflector.**

8. **Unplug the lamp or lamps needing replacement.**

9. Use a **new UV lamp** and plug it into the white socket.

NOTE: Always wear cotton gloves when handling a new UV lamp.

10. Gently press the lamp into the reflector brackets.

11. **Replace the QUATTRO in the duct opening in the correct position and screw it back.**

12. **Unscrew the locking screw and open the cover.**

13. **Reinstall the armored cable through the EMT fitting.**

14. **Reconnect the building's power wires to the three orange connectors.** Refer to installation step 10.

Get In Touch

 **Call:** 0845 6880112
 **Email:** info@adremit.co.uk

Our Address

Puravent, Adremit Limited, Unit 5a, Commercial Yard,
Settle, North Yorkshire, BD24 9RH

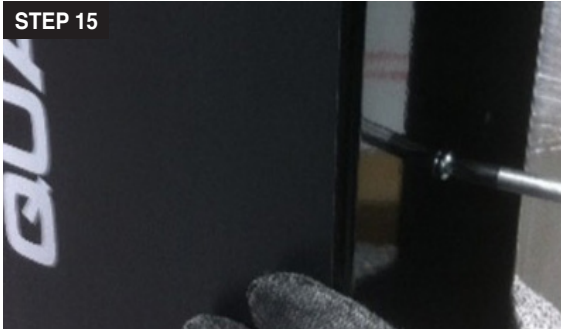

STEP 15

15. Close the cover and screw the locking screw.

STEP 16

16. Energize the unit by turning on its power source. **The unit can now be activated.**

How to Clean your Product

For optimal performance, the lamp(s) and filter(s) should be kept free of dust and residue deposit. Clean when necessary with mild soap or alcohol. To clean the unit exterior, use a damp cloth with general purpose detergent. Always spot test the cleaner to make sure it does not damage the surface.

⚠ CAUTION: Under no circumstance should water be sprayed or splashed onto the product.

STORAGE

The QUATTRO does not require specific storage. It is a portable unit that works continuously when ON, or automatically when selecting proper settings (fan speed and timer).

⚠ CAUTION: Keep away from unsupervised children. This unit is not a toy.

ULTRAVIOLETS: UVC

The UVC (254 nm) wavelengths produced by Sanuvox UV units and systems are the same as the ultraviolets produced by the Sun. The UVC attacks the micro-organisms on a molecular level deactivating the contaminants. Unlike conventional UV lamps on the market, Sanuvox UV units and systems use a patented process designed to deliver the maximum UV dosage to the moving airstream or surface.



⚠ CAUTION: Never expose eyes or skin to an operating UV lamp.

ELECTRICAL RATINGS, POWER CONSUMPTION & AVAILABLE VOLTAGE

The QUATTRO has a power consumption of 160 watts and requires a 120/230VAC, 50/60Hz power source. See product label to confirm power consumption of your specific unit or system.

NOTE: IF YOU EXPERIENCE A PROBLEM, PLEASE CONTACT CUSTOMER SERVICE FIRST OR SEE YOUR WARRANTY. DO NOT RETURN THE PRODUCT TO THE ORIGINAL PLACE OF PURCHASE. DO NOT ATTEMPT TO OPEN THE PRODUCT OR TAMPER WITH ITS COMPONENTS WITHOUT CONTACTING CUSTOMER SERVICE FIRST. DOING SO MAY VOID YOUR WARRANTY AND CAUSE PERSONAL INJURY OR DAMAGE TO THE PRODUCT.

Get In Touch

 **Call:** 0845 6880112
 **Email:** info@adremit.co.uk

Our Address

Puravent, Adremit Limited, Unit 5a, Commercial Yard,
 Settle, North Yorkshire, BD24 9RH



TROUBLESHOOTING

If your product is not working properly, refer to the following.

What you will need

A Phillips No. 2 screwdriver, a non-magnetic 5/16" nutdriver and spare parts.

Problem	Possible Cause	Solution
The switch does not illuminate.	- There is no power to the electrical outlet.	- Check the outlet for power and check the QUATTRO circuit breaker. - Start the HVAC fan.
The Red LED (ballast) is lit and the Amber LED (lamp) is not.	- one of the lamp is defective.	- check the lamp to ensure that it is not a defect in the lamp sensing circuit in the ballast. This is done by using an ohmmeter to check the two filaments on the lamp. See "A. Step by Step Lamp Test" instructions on page 11.

Contact your contractor for all your needs in terms of replacement parts: mounting frame, circuit breaker, UV lamps, etc.

A. Step by Step Lamp Test



1. Disconnect the socket from the lamp.

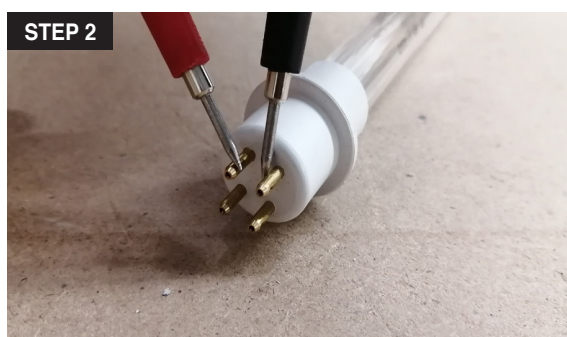

2. Placing the probe of the ohmmeter to one of the four pins on the end of the lamp, touch the other probe of the ohmmeter to each of the other pins until you find the matching pin.

The ohmmeter will read approximately 3 ohms (almost a short). This indicates that the filament is good. Check the other two pins. If both sets of filaments test OK, the lamp is functioning.

If one or both sets of filaments read an open circuit (infinity) on resistance, the lamp is defective.

Get In Touch

Call: 0845 6880112
Email: info@adremit.co.uk

Our Address

Puravent, Adremit Limited, Unit 5a, Commercial Yard, Settle, North Yorkshire, BD24 9RH



WARRANTY

You should first read all instructions before attempting to use this product.
For this warranty to be valid, keep a copy of the proof of purchase.



UV lamp	2 years
Ballast	3 years
Electronic components	3 years

- A. This limited warranty applies to repair or replacement of product found to be defective in material or workmanship. This warranty does not apply to damage resulting from abusive, unreasonable use or supplemental damage. Defects that are the result of normal wear and tear will not be considered manufacturing defects under this warranty.
SANUVOX IS NOT LIABLE FOR INCIDENTAL OR CONSEQUENTIAL DAMAGES OF ANY NATURE, ANY IMPLIED WARRANTY OF MERCHANTABILITY OR FITNESS FOR A PARTICULAR PURPOSE ON THIS PRODUCT IS LIMITED IN DURATION TO THE DURATION OF THIS WARRANTY.
Some jurisdictions **do not** allow the exclusion or limitation of incidental or consequential damages or limitation on how long an implied warranty last, so the above limitations or exclusions may not apply to you. This warranty gives specific legal rights, and you also may have other rights which vary from jurisdiction to jurisdiction. This warranty applies only to the original purchaser of this product from the original date of purchase.
- B. At its option, SANUVOX will repair or replace this product if it is found to be defective in material or workmanship.
- C. This warranty does not cover damage resulting from any unauthorized attempts to repair or from any use not in accordance with the instruction manual.
- D. This warranty does not cover the filters, pre-filters or other accessories (if included), except for material or workmanship defects.

Call us toll-free at 1-888-726-8869 or email: info@sanuvorex.com
Please be sure to specify product name.

NOTE: IF YOU EXPERIENCE A PROBLEM, PLEASE CONTACT CUSTOMER SERVICE FIRST OR SEE YOUR WARRANTY. DO NOT RETURN THE PRODUCT TO THE ORIGINAL PLACE OF PURCHASE. DO NOT ATTEMPT TO OPEN THE PRODUCT OR TAMPER WITH ITS COMPONENTS WITHOUT CONTACTING CUSTOMER SERVICE FIRST. DOING SO MAY VOID YOUR WARRANTY AND CAUSE PERSONAL INJURY OR DAMAGE TO THE PRODUCT.

CUSTOMER SERVICE

TO ORDER REPLACEMENT PARTS

PLEASE CONTACT YOUR CONTRACTOR OR SANUVOX CUSTOMER SERVICE
Toll-Free Phone #: 1-888-726-8869
Email: info@sanuvorex.com
Website: www.sanuvorex.com
Please be sure to specify product name.

Replacement parts for this product

BST120/277GL	Ballast with input of 120/277VAC, 50/60Hz
LMPHGS180	18" UV straight lamp, germicidal

⚠ WARNING: Use only specified SANUVOX branded replacement UV lamps with your unit or system. Use of any other lamps will void your warranty and can result in damage to the unit, system and/or lamp(s).

Get In Touch

Call: 0845 6880112
 Email: info@adremit.co.uk

Our Address

Puravent, Adremit Limited, Unit 5a, Commercial Yard,
Settle, North Yorkshire, BD24 9RH

