



The luxury hot water air heater

The Mark TANNER FBA is an aesthetically attractive water-supplied suspended air heater with an axial fan.

The FBA is supplied with a powder coating as standard. The unit is supplied in four different models with varying air inlets and outlets. With its low height, the FBA is suitable to heat rooms with low ceilings.

The TANNER FBA is a low maintenance and silent air heater. This unit can be used to heat a showroom in a short period of time.

The FBA is designed for use in showrooms, offices, changing rooms and shops.

Features:

- Attractive appearance
- Simple installation
- Low maintenance
- Powerful fan

Optional: Design plate for optically concealing the TANNER FBA in the suspended ceiling. Prices and information on request.



Remote connection possible with the PinTherm Connect!

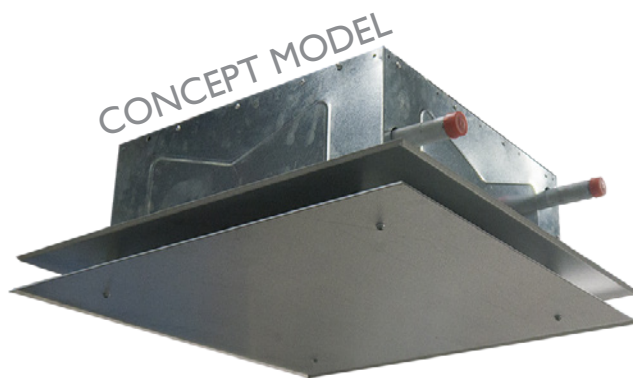

mark[®]

Get In Touch

Call: 0845 6880112
Email: info@adremit.co.uk

Our Address

Puravent, Adremit Limited, Unit 5a, Commercial Yard,
Settle, North Yorkshire, BD24 9RH

Dimensions

Type	a	b	g
FBA 600 V	600	568	388
FBA 700 V	750	718	524
FBA 800 V	850	818	624

V MODEL

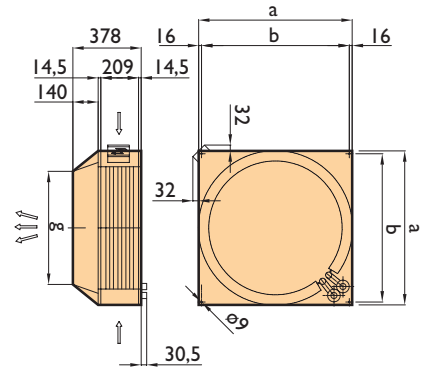
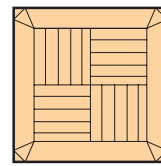

HI MODEL

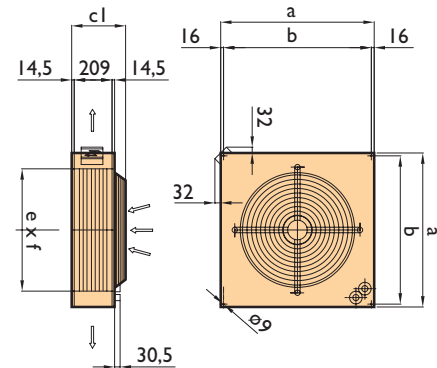
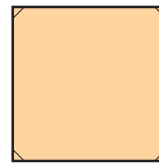

Type	a	b	c	cl	e	f
FBA 600 H	600	568	302	289	425	152
FBA 700 H	750	718	306	293	575	152
FBA 800 H	850	818	312	299	675	152

H2 MODEL

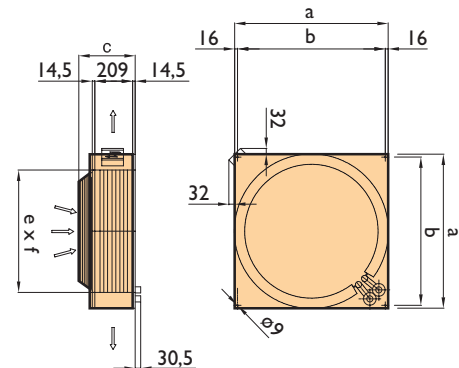
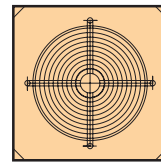

General data:

- Strip spacing: 2.1mm
- Water side connection: 1" external thread
- Drainage connection: 1/8"
- Maximum water inlet temperature: 120°C
- Maximum working pressure: 16 bar
- Maximum room temperature: ± 40 °C

Technical information

Type		621-623	631-633	721-723	731-733	821-823	831-833
90/70 T I5	kW	21,1	28,0	30,5	40,6	45,7	50,6
Air outlet temperature at the exchanger	°C	42	51	41	50	40	50
70/50 T I5	kW	17,3	23,0	25,0	33,3	32,5	41,5
Air outlet temperature at the exchanger	°C	40	49	39	48	38	48
60/40 T I5	kW	10,1	13,5	14,8	19,8	19,4	24,9
Air outlet temperature at the exchanger	°C	30	35	29	35	29	35
Speed	rpm	1320	1320	1320	1350	860	860
Air displacement	m³/h	1950	1930	2940	2900	3990	3665
Noise level (3m)	dB(A)	55	55	65	59	60	60
Weight without accessories (type H/V)	kg	23/28	25/30	35/42	18/44	42/50	45/53
Consumed current 400V / 230V	A	0,2/1,0	0,2/1,0	0,5/1,9	0,5/1,9	0,8/2,1	0,8/2,1

Get In Touch

Call: 0845 6880112
Email: info@adremit.co.uk

Our Address

Puravent, Adremit Limited, Unit 5a, Commercial Yard, Settle, North Yorkshire, BD24 9RH

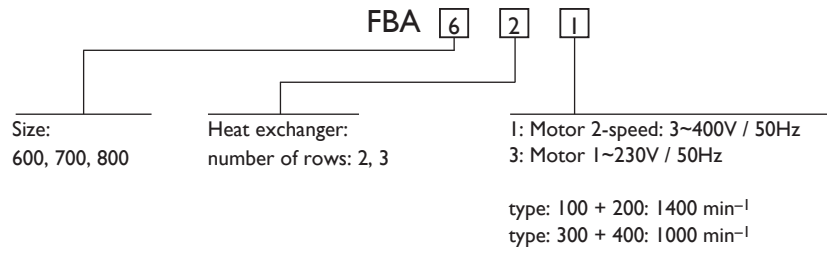

Assembly/location suggestions

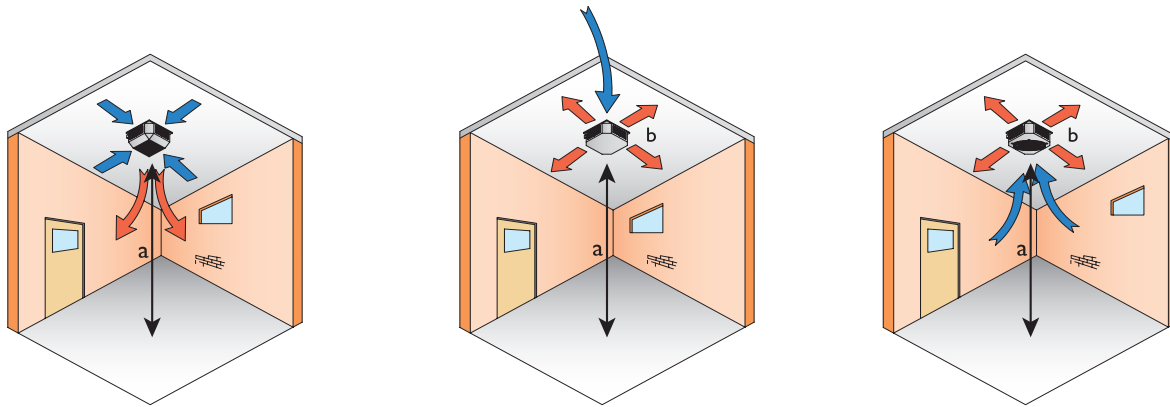

Type V

Type	a (m)
FBA 600	4,0
FBA 700	4,5
FBA 800	5,0

Type H1

Type	a (m)	b
FBA 600	2,5	4
FBA 700	2,8	4,8
FBA 800	3,4	5

Type H2

Type	a (m)	b
FBA 600	2,5	4
FBA 700	2,8	4,8
FBA 800	3,4	5

Controls

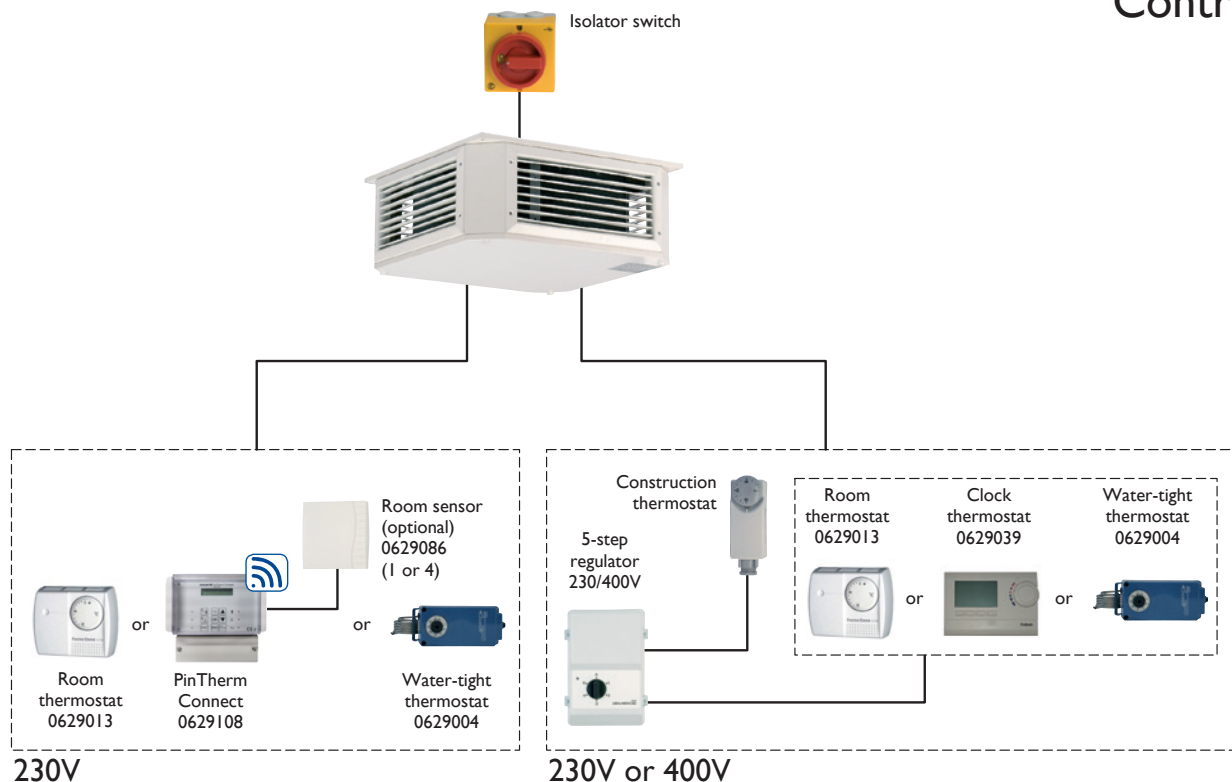

Hot water-supplied air heaters - 58

Get In Touch

Call: 0845 6880112
Email: info@adremit.co.uk

Our Address

Puravent, Adremit Limited, Unit 5a, Commercial Yard, Settle, North Yorkshire, BD24 9RH