



K 150 XL SILEO

Item no. 25363

Version: 50 Hz

Document type: **Product card**
 Document date: **2019-07-16**
 Generated by: **Systemair Online Catalogue**



Description

- Speed-controllable
- Quiet-running
- Increased efficiency
- Integral thermal contacts
- Can be installed in any position
- Can be installed outdoors
- Maintenance-free and reliable

The K Sileo series is designed for installation in ducts. All K-fans have a minimum 25 mm long spigot connections.

The fans have backward-curved blades and external rotor motors. To simplify the installation the K Sileo fan has a fixing bracket together with screws for mounting the bracket included as standard. The FK mounting clamp facilitates easy installation and removal, and prevents the transfer of vibration to the duct. The fans can be speed-controlled via a stepless thyristor or a 5-step transformer. To protect the motor from overheating the fan has integral thermal contacts with manual reset.

The casing is manufactured from galvanised sheet steel and folded which gives the fan a close to air tight casing. Duct connected outdoor and wet room applications of the fan are possible due to the air tight casing. The K-fans have corrosion class C3.



Technical parameters

Nominal data		
Voltage	230	V
Frequency	50	Hz
Phase	1	~
Input power (P1)	100	W
Current	0,443	A
Max. airflow	0,201	m³/s
R.p.m.	2523	r.p.m.
Capacitor	2,5	µF
Weight	4,1	kg
Temperature data		
Max. temperature of transported air	70	°C
Max. temperature of transported air when speed-controlled	70	°C
Sound data		
Sound pressure level at 3 m	47,6	dB(A)

Get In Touch

Call: [0845 6880112](tel:08456880112)
 Email: info@adremit.co.uk

Our Address

Puravent, Adremit Limited, Unit 5a, Commercial Yard,
 Settle, North Yorkshire, BD24 9RH



Protection / Classification

Insulation class	F
Enclosure class, motor	IP44

ErP

Energy class, basic unit	E
Energy class, basic unit option	C
ErP ready	ErP 2016/ErP 2018

Diagrams

Diagrams

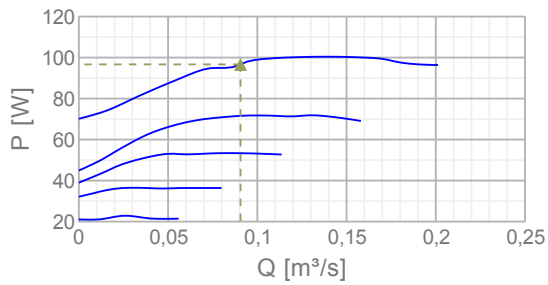
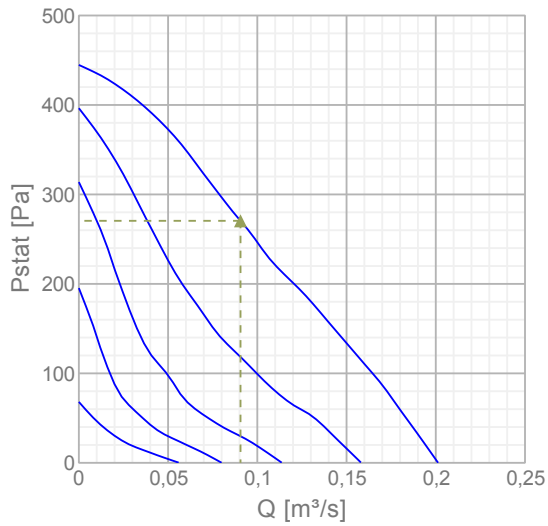

Max efficiency

Hydraulic data										
▲ Working air flow										0,0906 m³/s
▲ Working static pressure										271 Pa
▲ Power										96,7 W
Speed										2556 r.p.m.
Current										0,427 A
SFP										1,07 W/(l/s)
Voltage										230 V
Sound power level		63	125	250	500	1k	2k	4k	8k	Tot
Inlet	dB(A)	50	75	67	71	67	62	59	49	78
Outlet	dB(A)	53	71	62	68	64	62	55	49	74
Surrounding	dB(A)	15	33	37	50	46	47	44	30	53

Name: **K 150 XL SILEO** | Item no.: **25363** | Version: **50 Hz**

2 / 5

Document type: **Product card** | Document date: **2019-07-16** | Generated by: **Online catalogue**

Get In Touch

Call: [0845 6880112](tel:08456880112)
 Email: info@adremit.co.uk

Our Address

Puravent, Adremit Limited, Unit 5a, Commercial Yard,
 Settle, North Yorkshire, BD24 9RH

Dimensions

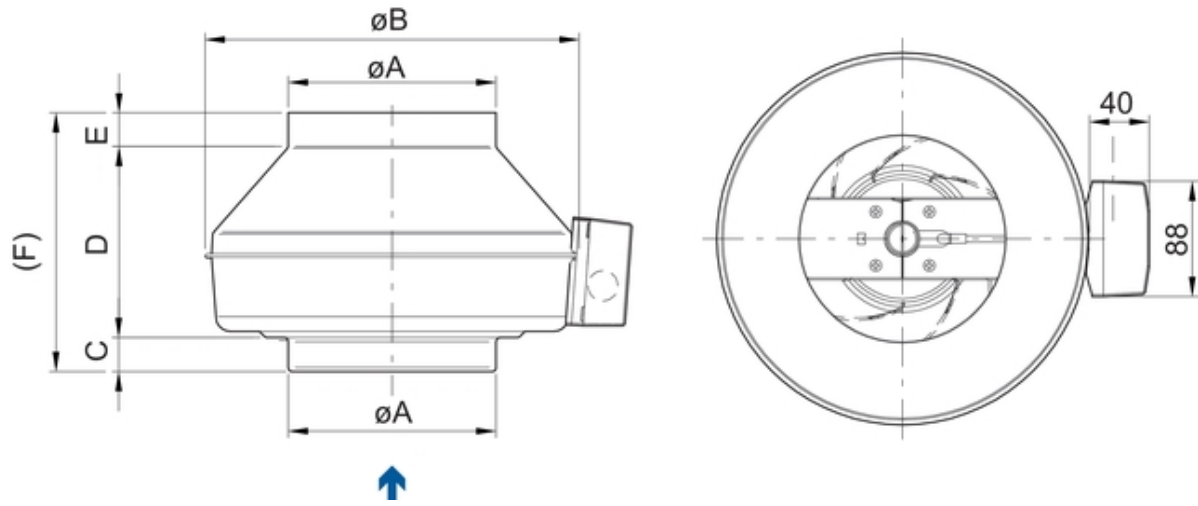

	øA	øB	C	D	E	F
K 150 M sileo	149	286	25	152	25	202
K 150 XL sileo	149	336	29	171	26	226

Get In Touch

Call: [0845 6880112](tel:08456880112)
 Email: info@adremit.co.uk

Our Address

Puravent, Adremit Limited, Unit 5a, Commercial Yard,
 Settle, North Yorkshire, BD24 9RH



Wiring

230V 1~

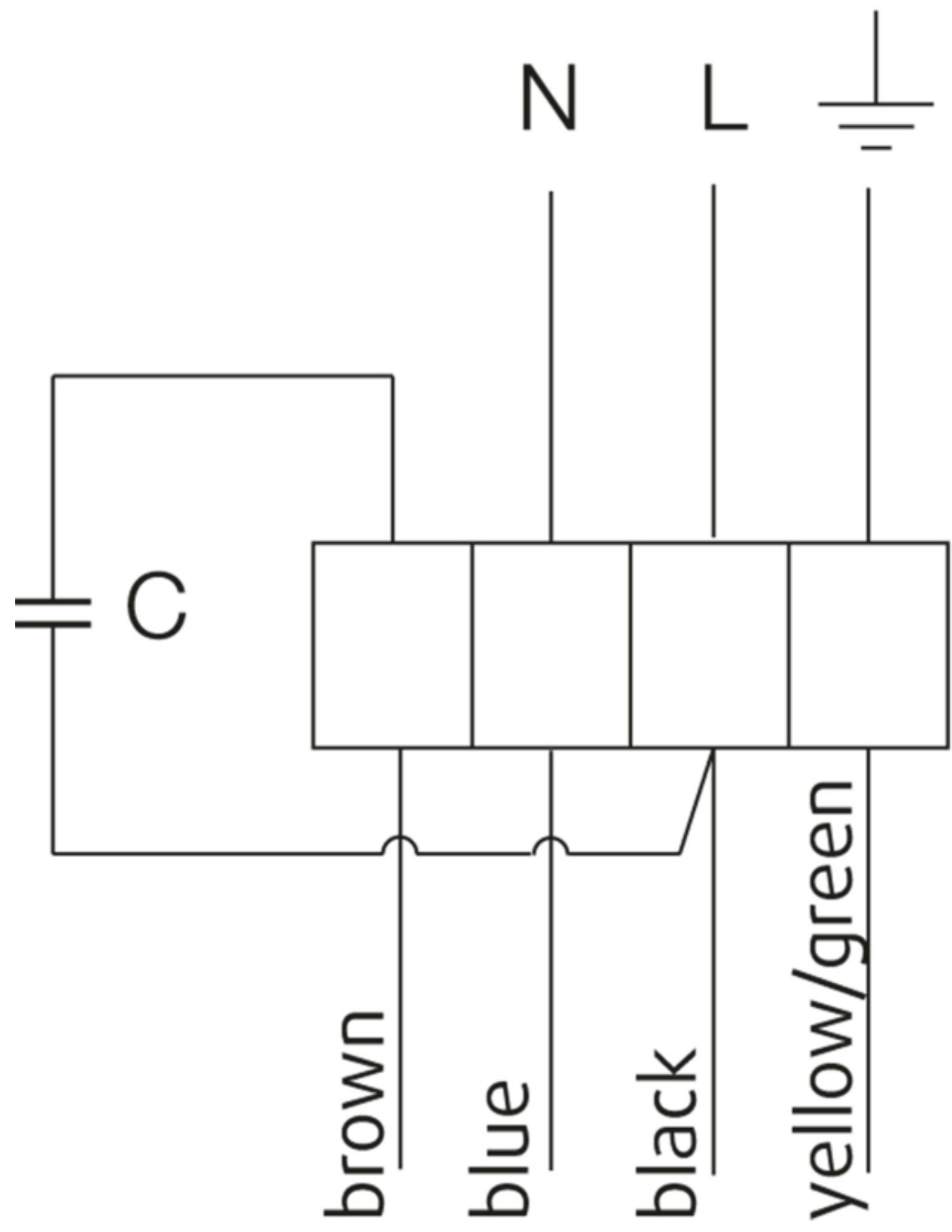

Name: **K 150 XL SILEO** | Item no.: **25363** | Version: **50 Hz**
Document type: **Product card** | Document date: **2019-07-16** | Generated by: **Online catalogue**

Get In Touch

Call: [0845 6880112](tel:08456880112)
 Email: info@adremit.co.uk

Our Address

Puravent, Adremit Limited, Unit 5a, Commercial Yard,
Settle, North Yorkshire, BD24 9RH



Accessories

Electric accessories

[RE 1.5 Speed control \(5000\)](#)
[REU 1.5 Speed control \(5004\)](#)
[REE 1 Speed control \(5314\)](#)
[REPT 6 Digital regulator \(5698\)](#)
[RT 0-30 Room Thermostat \(5151\)](#)
[CO2RT-R-D Transmitter \(6993\)](#)
[Presence detector/IR24-P \(6995\)](#)
[RETP 6 Temp/Pressure regulator \(32293\)](#)
[STL 1.5 Speed controller \(84251\)](#)
[REV-3POL/03 ON/OFF \(33978\)](#)
[FRQS-E-6A \(37419\)](#)
[FRQ5S-E-6A \(37421\)](#)
[DTV500A \(96807\)](#)

Accessories

[CB 150-1.2 230V/1 Duct heater \(5378\)](#)
[CB 150-2.1 230V/1 Duct heater \(5379\)](#)
[CB 150-2.7 230V/1 Duct heater \(5380\)](#)
[CBM 150-2.1 230V/1 Duct heater \(5481\)](#)
[LDC 150-600 Silencer \(5199\)](#)
[FFR 150 Filter cassette \(1769\)](#)
[FGR 150 Filter cassette \(1807\)](#)
[FK 150 Fast clamp \(1609\)](#)
[IGK-160 Wall Grid \(1632\)](#)
[SG 150 Protection guard \(5555\)](#)
[RSK-150 Back draft damper \(5599\)](#)
[THB 160 Hood w. cover pl. Red \(2034\)](#)
[THB 160 Hood w.cover pl. black \(1764\)](#)
[THS 160 Hood w.cover pl. black \(1839\)](#)
[THS 160 Hood w. cover pl. Red \(2044\)](#)
[LDC 150-300 Silencer \(53723\)](#)
[CB 150-5.0 400V/2 Duct heater \(5381\)](#)

Documentation

 [202341_Fans_Instructions_CE_A010.pdf \(1,83MB\)](#)

 [K fan mounting.wmv \(3,48MB\)](#)

Specification text

Name: **K 150 XL SILEO** | Item no.: **25363** | Version: **50 Hz**

Document type: **Product card** | Document date: **2019-07-16** | Generated by: **Online catalogue**

5 / 5

Get In Touch

 **Call:** [0845 6880112](tel:08456880112)
 **Email:** info@adremit.co.uk

Our Address

Puravent, Adremit Limited, Unit 5a, Commercial Yard,
Settle, North Yorkshire, BD24 9RH