



K 125 M SILEO

Item no. 1002

Version: 50 Hz



Description

- Speed-controllable
- Integral thermal contacts
- Can be installed in any position
- Can be installed outdoors
- Maintenance-free and reliable

The K series is designed for installation in ducts. All the K-fans have minimum 25 mm long spigot connections.

The fans have backward-curved blades and external rotor motors. To simplify the installation the K-fan has a fixing bracket together with screws for mounting the bracket included as standard. The FK mounting clamp (as accessorie) prevents the transfer of vibration to the duct. The fans can be speed-controlled via a stepless thyristor or a 5-step transformer.

To protect the motor from overheating the fan is impedance protected. The casing is manufactured from galvanised sheet steel and folded which gives the fan a close to air tight casing. Duct connected outdoor and wet room applications of the fan are possible due to the air tight casing. The K-fans have corrosion class C3.



Technical parameters

Nominal data		
Voltage	230	V
Frequency	50	Hz
Phase	1	~
Input power (P1)	28,2	W
Current	0,164	A
Max. airflow	0,0519	m³/s
R.p.m.	2491	r.p.m.
Weight	2,3	kg
Temperature data		
Max. temperature of transported air	70	°C
Max. temperature of transported air when speed-controlled	70	°C
Sound data		
Sound pressure level at 3 m	34,2	dB(A)
Protection / Classification		
Insulation class		B
Enclosure class, motor		IP44

Get In Touch

Call: [0845 6880112](tel:08456880112)
 Email: info@adremit.co.uk

Our Address

Puravent, Adremit Limited, Unit 5a, Commercial Yard,
 Settle, North Yorkshire, BD24 9RH



ErP

Energy class, basic unit

F

Energy class, basic unit option

C

ErP ready

ErP 2018

Energy class label

Energy class, basic unit

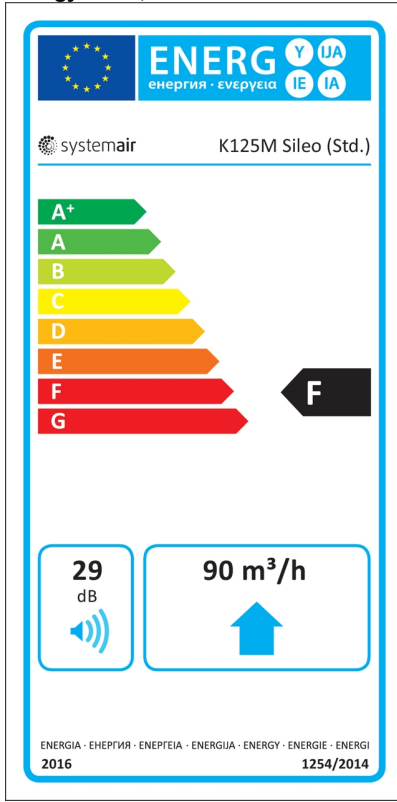

Name: **K 125 M SILEO** | Item no.: **1002** | Version: **50 Hz**

2 / 6

Document type: **Product card** | Document date: **2019-07-16** | Generated by: **Online catalogue**

Get In Touch



Call: [0845 6880112](tel:08456880112)



Email: info@adremit.co.uk

Our Address

Puravent, Adremit Limited, Unit 5a, Commercial Yard,
Settle, North Yorkshire, BD24 9RH

Energy class, unit with local demand control

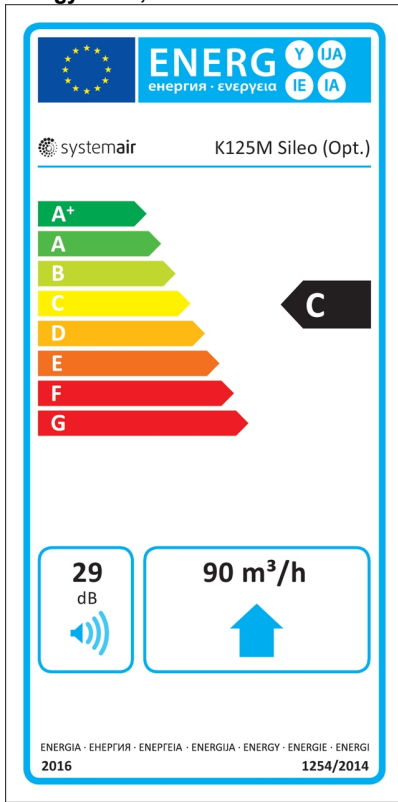

Diagrams

Diagrams

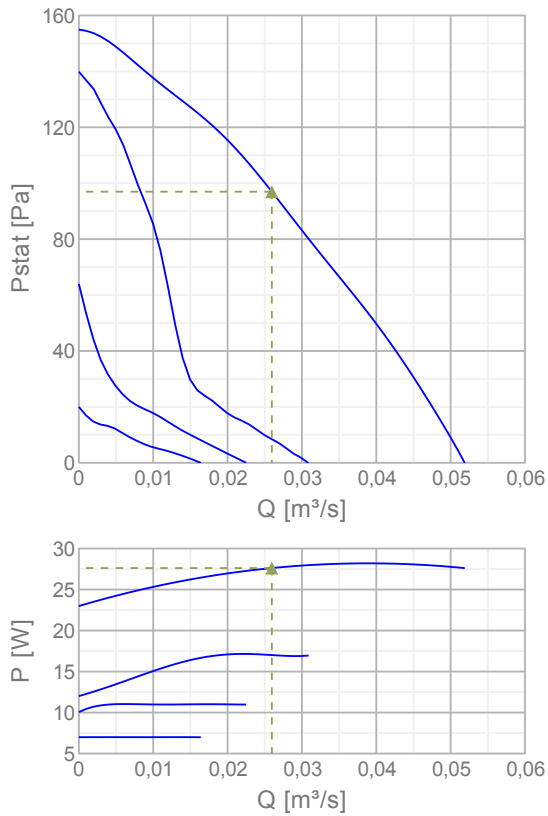

Name: **K 125 M SILEO** | Item no.: **1002** | Version: **50 Hz**

Document type: **Product card** | Document date: **2019-07-16** | Generated by: **Online catalogue**

Get In Touch

Call: [0845 6880112](tel:08456880112)
 Email: info@adremit.co.uk

Our Address

Puravent, Adremit Limited, Unit 5a, Commercial Yard,
 Settle, North Yorkshire, BD24 9RH

Max efficiency

Hydraulic data										
▲ Working air flow										0,0259 m ³ /s
▲ Working static pressure										97 Pa
▲ Power										27,6 W
Speed										2529 r.p.m.
Current										0,161 A
SFP										1,06 W/(l/s)
Voltage										230 V
Sound power level		63	125	250	500	1k	2k	4k	8k	Tot
Inlet	dB(A)	45	53	57	58	52	48	32	24	62
Outlet	dB(A)	44	51	55	57	51	47	35	24	60
Surrounding	dB(A)	17	26	30	36	35	31	20	15	40

Dimensions

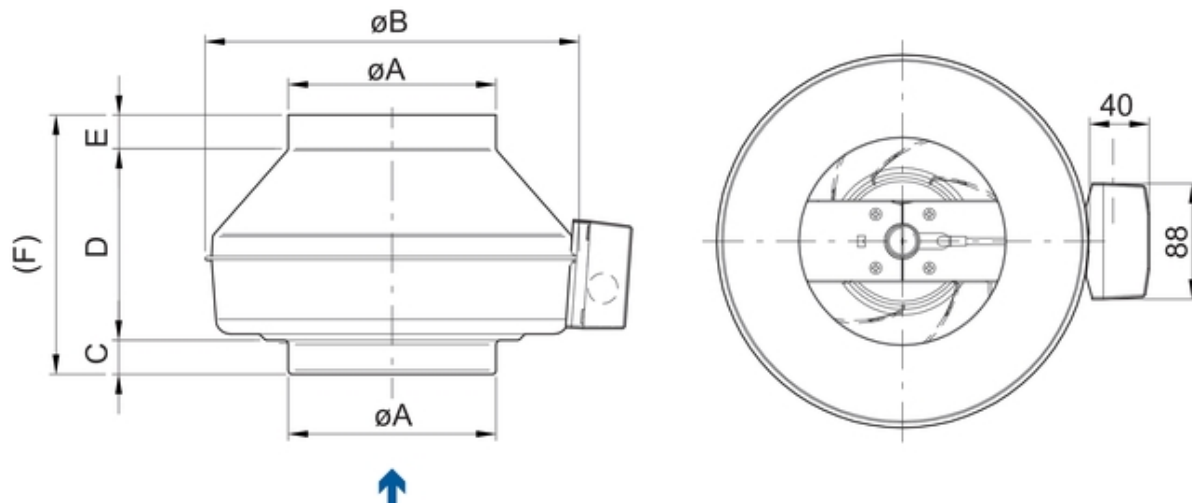

K	øA	øB	C	D	E	F
100 M	99	218	26	166	26	218
100 XL	99	246	26	161	26	213
125 M	124	218	27	142	27	196
125 XL	124	246	26	151	26	203
160 M	159	286	25	147	26	198
160 XL	159	336	29	166	26	221
200 M	199	336	30	148	27	205
200 L	199	336	30	174	27	231
250 M	249	336	30,5	119,5	27	177
250 L	249	336	30,5	144,5	27	202
315 M	314	408	32,5	160,5	27	220
315 L	314	408	38	161	27	225

Name: **K 125 M SILEO** | Item no.: **1002** | Version: **50 Hz**

Document type: **Product card** | Document date: **2019-07-16** | Generated by: **Online catalogue**

4 / 6

Get In Touch

Call: [0845 6880112](tel:08456880112)
 Email: info@adremit.co.uk

Our Address

Puravent, Adremit Limited, Unit 5a, Commercial Yard,
 Settle, North Yorkshire, BD24 9RH

Wiring

230V 1~

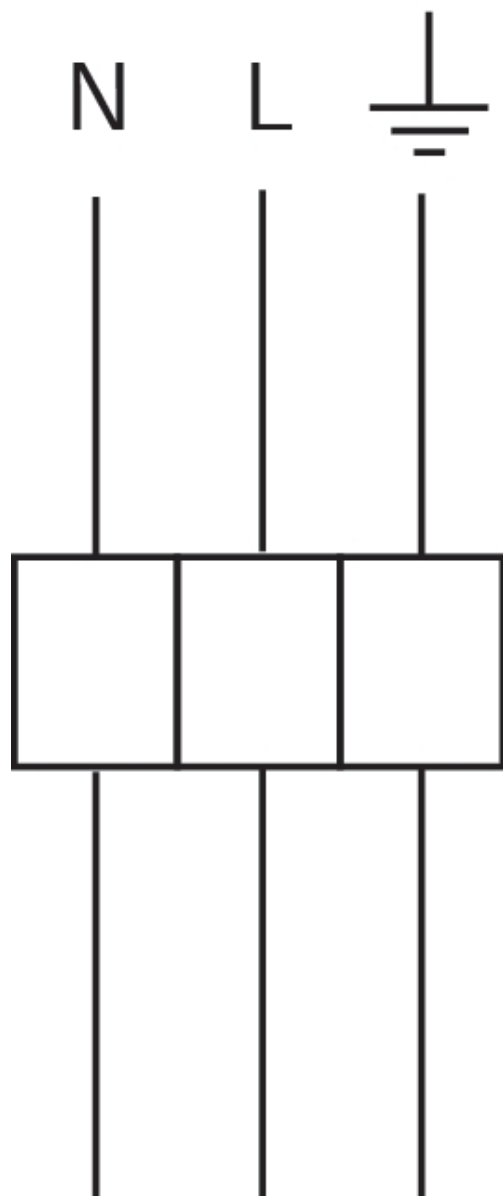

Accessories

Electric accessories

[RE 1,5 Speed control \(5000\)](#)

[REU 1.5 Speed control \(5004\)](#)

[REE 1 Speed control \(5314\)](#)

[REPT 6 Digital regulator \(5698\)](#)

[RT 0-30 Room Thermostat \(5151\)](#)

[CO2RT-R-D Transmitter \(6993\)](#)

[Presence detector/IR24-P \(6995\)](#)

[RETP 6 Temp/Pressure regulator \(32293\)](#)

[STL 1.5 Speed controller \(84251\)](#)

[REV-3POL/03 ON/OFF \(33978\)](#)

[FRQS-E-6A \(37419\)](#)

[FRQ5S-E-6A \(37421\)](#)

[DTV500A \(96807\)](#)

Name: **K 125 M SILEO** | Item no.: **1002** | Version: **50 Hz**

Document type: **Product card** | Document date: **2019-07-16** | Generated by: **Online catalogue**

5 / 6

Get In Touch



Call: [0845 6880112](tel:08456880112)



Email: info@adremit.co.uk

Our Address

Puravent, Adremit Limited, Unit 5a, Commercial Yard,
Settle, North Yorkshire, BD24 9RH

Accessories

[CB 125-0,6 230V/1 Duct heater \(5289\)](#)
[CB 125-1,2 230V/1 Duct heater \(5290\)](#)
[CB 125-1,8 230V/1 Duct heater \(5377\)](#)
[CBM 125-1,2 230V/1 Duct heater \(5480\)](#)
[VBF 125 Water heating battery \(1730\)](#)
[CWX 125-3-2,5 Duct cooler,circ \(30021\)](#)
[VBC 125-2 Water heating batt \(5457\)](#)
[LDC 125-600 Silencer \(5190\)](#)
[LDC 125-900 Silencer \(5191\)](#)
[FFR 125 Filter cassette \(1768\)](#)
[FGR 125 Filter cassette \(1804\)](#)
[FK 125 Fast clamp \(1608\)](#)
[VKK-125 Back draft damper \(1624\)](#)
[IGK-125 Wall Grid \(1631\)](#)
[RSK-125 Back draft damper \(5598\)](#)
[SG 125 Protection guard \(5607\)](#)
[LDC 125-1200 Silencer \(5997\)](#)
[THB 160 Hood w. cover pl. Red \(2034\)](#)
[THB 160 Hood w.cover pl. black \(1764\)](#)
[THS 160 Hood w.cover pl. black \(1839\)](#)
[THS 160 Hood w. cover pl. Red \(2044\)](#)
[VBC 125-3 Water heating batt \(9839\)](#)
[LDC 125-300 Silencer \(53722\)](#)

Documentation



202341_Fans_Instructions_CE_A010.pdf (1,83MB)



Certificate S-mark K 1211224.pdf (1,32MB)



K fan mounting.wmv (3,48MB)

Specification text

K 125M Circular duct fan made of steel
DN 125, 230V/50Hz, 1~, imp. backw. curved

Centrifugal circular duct fan designed for easy and direct installation in ducts.

The casing is manufactured from galvanised sheet steel and airtight folded, air leakage class C acc. to EN 12237:2003
Circular connection spigot, length 25mm, acc. to EN1506:1997

Free-running, backward curved centrifugal impeller made of plastic.

Balancing made to G 6.3, motor compl. with impeller statically and dynamically balanced in two planes acc. to DIN ISO 1940 T.1.

Voltage controllable external rotor motor

(IP44), maintenance-free, the motor is placed inside the air flow for cooling. Integral thermal contacts with manual reset acc. to EN 60335-2-80,
speed-controlled via a 5-step transformer or a stepless thyristor. Silent, long-life ball bearings. Terminal box (IP55) on the casing

Mounting bracket included in delivery (unmounted).

For indoor, outdoor installation as well as in wet areas.

PRODUCT: SYSTEMAIR

TYPE: K 125M

Item no. 1002

Name: **K 125 M SILEO** | Item no.: **1002** | Version: **50 Hz**

Document type: **Product card** | Document date: **2019-07-16** | Generated by: **Online catalogue**

6 / 6

Get In Touch



Call: [0845 6880112](tel:08456880112)



Email: info@adremit.co.uk

Our Address

Puravent, Adremit Limited, Unit 5a, Commercial Yard,
Settle, North Yorkshire, BD24 9RH