



# K 100 XL SILEO

Item no. 25360

Version: 50 Hz



## Description

- Speed-controllable
- Quiet-running
- Increased efficiency
- Integral thermal contacts
- Can be installed in any position
- Can be installed outdoors
- Maintenance-free and reliable

The K Sileo series is designed for installation in ducts. All K-fans have a minimum 25 mm long spigot connections.

The fans have backward-curved blades and external rotor motors. To simplify the installation the K Sileo fan has a fixing bracket together with screws for mounting the bracket included as standard. The FK mounting clamp facilitates easy installation and removal, and prevents the transfer of vibration to the duct. The fans can be speed-controlled via a stepless thyristor or a 5-step transformer. To protect the motor from overheating the fan has integral thermal contacts with manual reset.

The casing is manufactured from galvanised sheet steel and folded which gives the fan a close to air tight casing. Duct connected outdoor and wet room applications of the fan are possible due to the air tight casing. The K-fans have corrosion class C3.



## Technical parameters

Nominal data		
Voltage	230	V
Frequency	50	Hz
Phase	1	~
Input power (P1)	52,1	W
Current	0,227	A
Max. airflow	0,0791	m³/s
R.p.m.	2418	r.p.m.
Capacitor	1,5	µF
Weight	3	kg
Temperature data		
Max. temperature of transported air	70	°C
Max. temperature of transported air when speed-controlled	70	°C
Sound data		
Sound pressure level at 3 m	45,2	dB(A)

### Get In Touch

Call: [0845 6880112](tel:08456880112)  
 Email: [info@adremit.co.uk](mailto:info@adremit.co.uk)

### Our Address

Puravent, Adremit Limited, Unit 5a, Commercial Yard,  
 Settle, North Yorkshire, BD24 9RH



## Protection / Classification

Insulation class	B
Enclosure class, motor	IP44

## ErP

Energy class, basic unit	E
Energy class, basic unit option	C
ErP ready	ErP 2016/ErP 2018

## Energy class label

### Energy class, basic unit

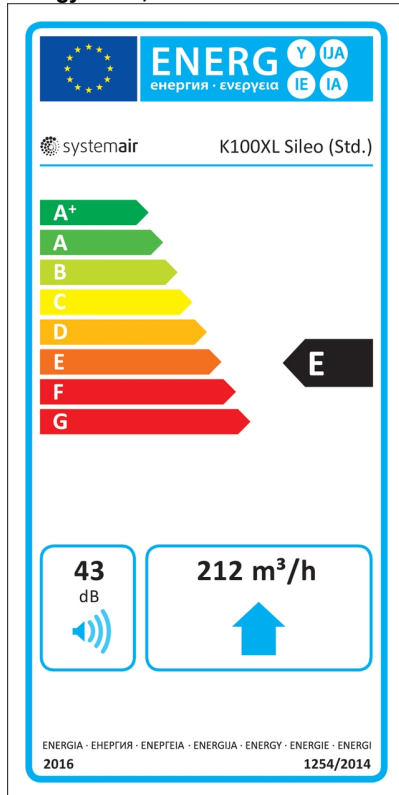

Name: **K 100 XL SILEO** | Item no.: **25360** | Version: **50 Hz**

Document type: **Product card** | Document date: **2019-07-16** | Generated by: **Online catalogue**

2 / 6

## Get In Touch

 Call: [0845 6880112](tel:08456880112)  
 Email: [info@adremit.co.uk](mailto:info@adremit.co.uk)

## Our Address

Puravent, Adremit Limited, Unit 5a, Commercial Yard,  
Settle, North Yorkshire, BD24 9RH

Energy class, unit with local demand control

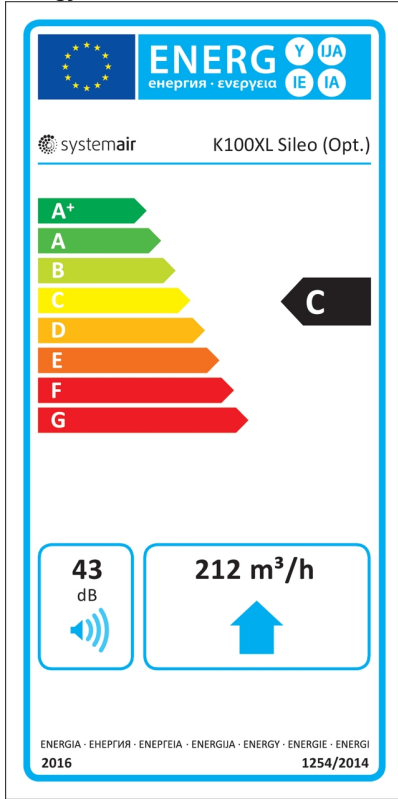

Diagrams

Diagrams

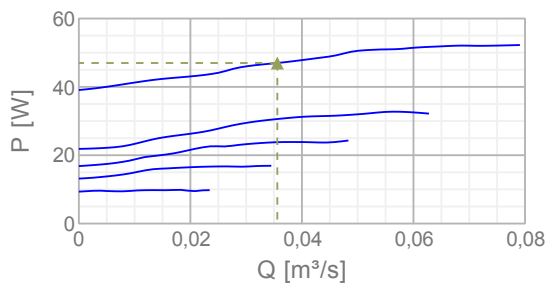
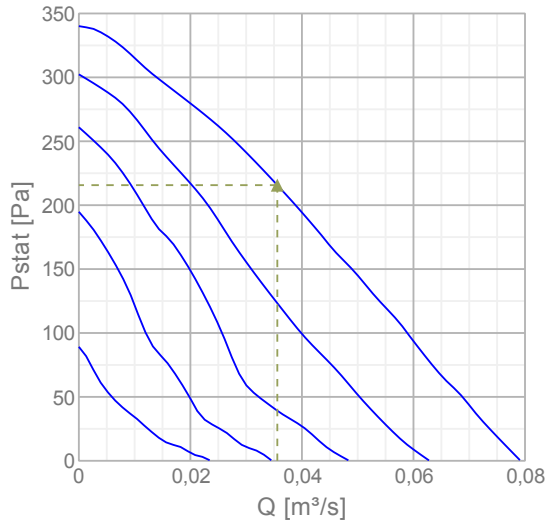

Name: **K 100 XL SILEO** | Item no.: **25360** | Version: **50 Hz**

Document type: **Product card** | Document date: **2019-07-16** | Generated by: **Online catalogue**

Get In Touch

Call: [0845 6880112](tel:08456880112)  
 Email: [info@adremit.co.uk](mailto:info@adremit.co.uk)

Our Address

Puravent, Adremit Limited, Unit 5a, Commercial Yard,  
 Settle, North Yorkshire, BD24 9RH

## Max efficiency

Hydraulic data										
▲ Working air flow										0,0356 m³/s
▲ Working static pressure										216 Pa
▲ Power										47 W
Speed										2549 r.p.m.
Current										0,207 A
SFP										1,32 W/(l/s)
Voltage										230 V
Sound power level		63	125	250	500	1k	2k	4k	8k	Tot
Inlet	dB(A)	54	65	62	65	64	60	52	40	71
Outlet	dB(A)	55	64	58	62	62	58	50	37	68
Surrounding	dB(A)	29	17	30	49	47	45	39	27	52

## Dimensions

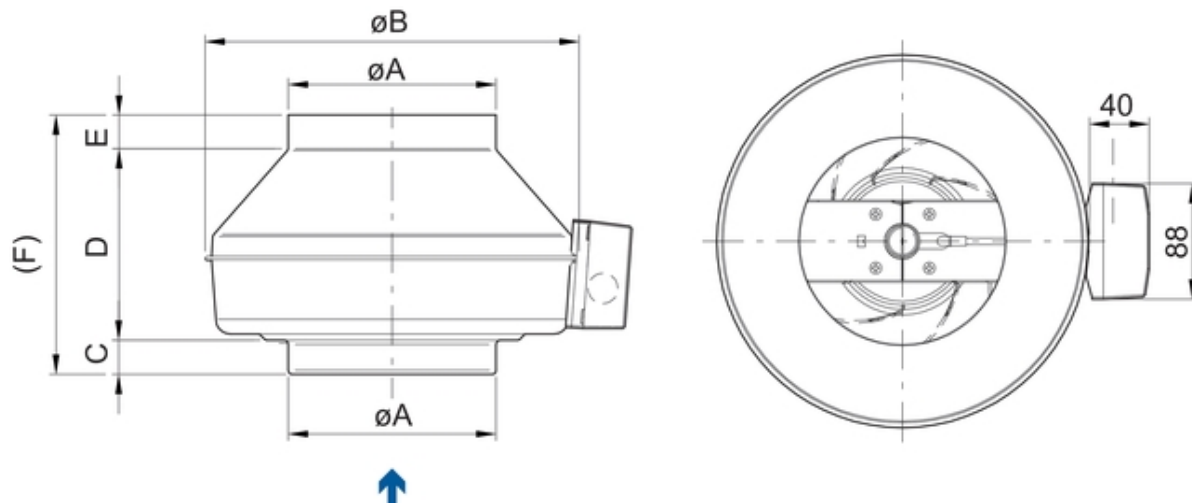

K	øA	øB	C	D	E	F
100 M	99	218	26	166	26	218
100 XL	99	246	26	161	26	213
125 M	124	218	27	142	27	196
125 XL	124	246	26	151	26	203
160 M	159	286	25	147	26	198
160 XL	159	336	29	166	26	221
200 M	199	336	30	148	27	205
200 L	199	336	30	174	27	231
250 M	249	336	30,5	119,5	27	177
250 L	249	336	30,5	144,5	27	202
315 M	314	408	32,5	160,5	27	220
315 L	314	408	38	161	27	225

Name: **K 100 XL SILEO** | Item no.: **25360** | Version: **50 Hz**

Document type: **Product card** | Document date: **2019-07-16** | Generated by: **Online catalogue**

4 / 6

### Get In Touch

Call: [0845 6880112](tel:08456880112)  
 Email: [info@adremit.co.uk](mailto:info@adremit.co.uk)

### Our Address

Puravent, Adremit Limited, Unit 5a, Commercial Yard,  
 Settle, North Yorkshire, BD24 9RH

230V 1~

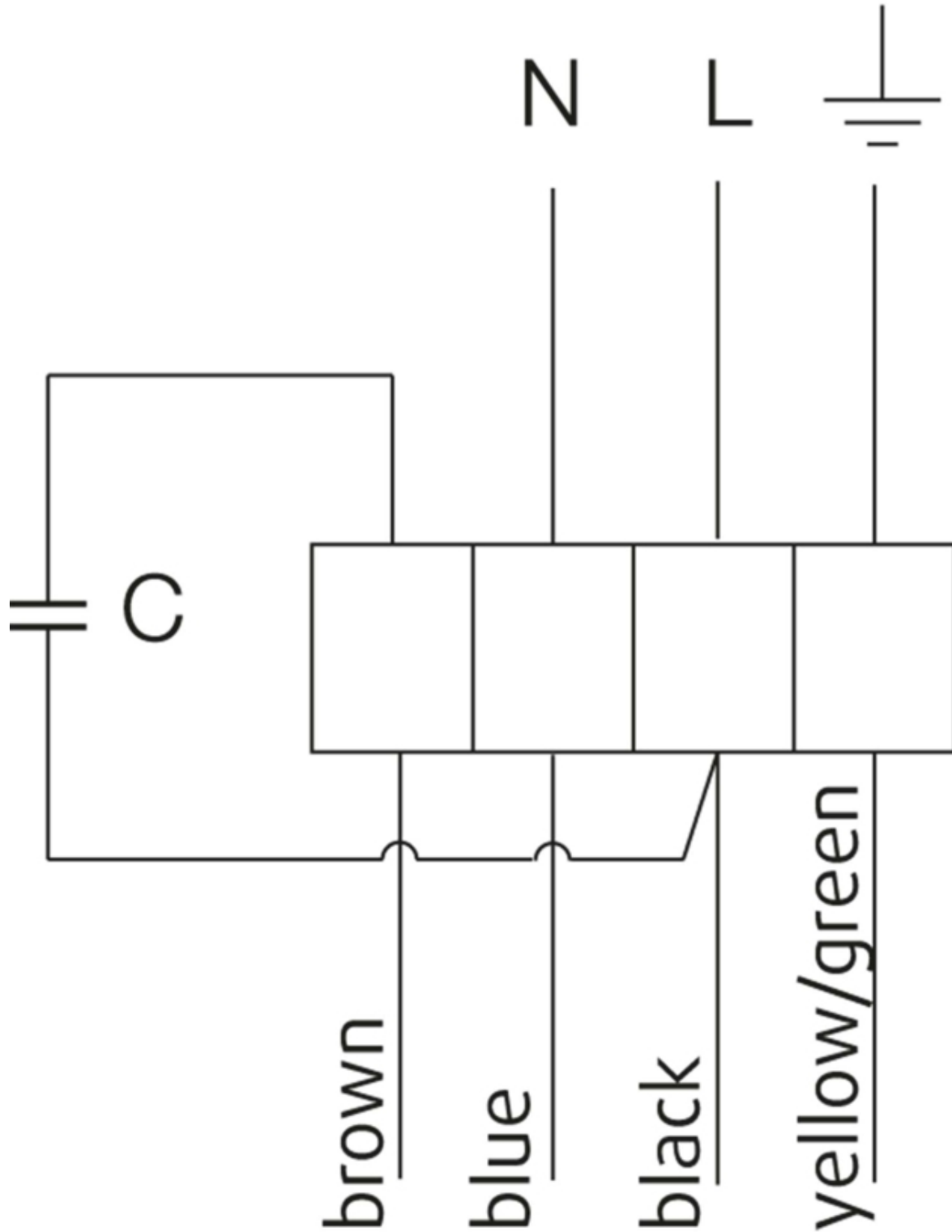

U1 = blue = blau  
U2 = black = schwarz  
Z = brown = braun  
PE = yellow/green = grün-gelb

### Get In Touch



Call: [0845 6880112](tel:08456880112)



Email: [info@adremit.co.uk](mailto:info@adremit.co.uk)

### Our Address

Puravent, Adremit Limited, Unit 5a, Commercial Yard,  
Settle, North Yorkshire, BD24 9RH

## Accessories

### Electric accessories

[RE 1.5 Speed control \(5000\)](#)  
[REU 1.5 Speed control \(5004\)](#)  
[REE 1 Speed control \(5314\)](#)  
[REPT 6 Digital regulator \(5698\)](#)  
[RT 0-30 Room Thermostat \(5151\)](#)  
[CO2RT-R-D Transmitter \(6993\)](#)  
[Presence detector/IR24-P \(6995\)](#)  
[RETP 6 Temp/Pressure regulator \(32293\)](#)  
[STL 1.5 Speed controller \(84251\)](#)  
[REV-3POL/03 ON/OFF \(33978\)](#)  
[FRQS-E-6A \(37419\)](#)  
[FRQ5S-E-6A \(37421\)](#)  
[DTV500A \(96807\)](#)

### Accessories

[CB 100-0.4 230V/1 Duct heater \(5288\)](#)  
[CB 100-0.6 230V/1 Duct heater \(5376\)](#)  
[CBM 100-0.6 230V/1 Duct heater \(5479\)](#)  
[VBF 100 Water heating battery \(1724\)](#)  
[CWK 100-3-2.5 Duct cooler.circ \(30019\)](#)  
[VBC 100-2 Water heating batt \(5456\)](#)  
[LDC 100-600 Silencer \(5188\)](#)  
[LDC 100-900 Silencer \(5189\)](#)  
[FFR 100 Filter cassette \(1766\)](#)  
[FGR 100 Filter cassette \(1802\)](#)  
[FK 100 Fast clamp \(1607\)](#)  
[VKK-100 Back draft damper \(1623\)](#)  
[IGK-100 Wall Grid \(1630\)](#)  
[RSK-100 Back draft damper \(5597\)](#)  
[SG 100 Protection guard \(5606\)](#)  
[LDC 100-300 Silencer \(8180\)](#)  
[LDC 100-1200 Silencer \(5996\)](#)  
[THB 160 Hood w. cover pl. Red \(2034\)](#)  
[THB 160 Hood w.cover pl. black \(1764\)](#)  
[THS 160 Hood w.cover pl. black \(1839\)](#)  
[THS 160 Hood w. cover pl. Red \(2044\)](#)  
[VBC 100-3 Water heating batt \(9838\)](#)

## Documentation



 [202341\\_Fans\\_Instructions\\_CE\\_A010.pdf \(1,83MB\)](#)

 [K fan mounting.wmv \(3,48MB\)](#)

## Specification text

The Circular duct fan is reliable in operation and maintenance free and its box consists of electroplated steel plate. The pipe connection with a length of 25 millimetre according to EN 1506:1997 allows an easy assembling. A mounting bracket for easy installation is included. The FK mounting clamp facilitates easy installation and removal, and prevents the transfer of vibration to the duct. Furthermore the fan has a free wheeling radial impeller with backward curved impeller vane. The actuation is carried out by a maintenance free, speed controlled external rotor motor. Through dropping the tension, the fans can be speed controlled with the help of a stepless thyristor or a 5- step transformer. The K fans have integral thermal contacts with reset device according to EN 60335-2-80 for protecting the engine. For annealing the engine is designed inside the air flow. Completely with the impeller in two levels the engine is statically and dynamically weighed heavy according DIN ISO 1940. According to EN 12237:2003 the fane has a leakage performance class C. Through the airproofed box and the IP 55 classified terminal box with a IP 68 classified M20 cable connection an installation outside and in damp locations is possible.

### Get In Touch

 **Call:** [0845 6880112](tel:08456880112)  
 **Email:** [info@adremit.co.uk](mailto:info@adremit.co.uk)

### Our Address

Puravent, Adremit Limited, Unit 5a, Commercial Yard,  
Settle, North Yorkshire, BD24 9RH