



KV 250 L SILEO

Item no. 19519

Version: 50 Hz

Document type: **Product card**
 Document date: **2019-07-10**
 Generated by: **Systemair Online Catalogue**



Description

- Speed-controllable
- Quiet-running
- Increased efficiency
- Integral thermal contacts
- Can be installed in any position - duct or wall mounted
- Can be installed outdoors
- Maintenance-free and reliable

The KV sileo series is designed for installation in ducts. All KV-fans have minimum 25 mm long spigot connections. The FK mounting clamp facilitates easy installation and removal, and prevents the transfer of vibration to the duct. The fans have backward-curved blades and external rotor motors. KV sileo fans can be speed-controlled via a stepless thyristor or a 5-step transformer.

To protect the motor from overheating the fan has integral thermal contacts with manual reset.

The casing is manufactured from galvanised sheet steel and folded which gives the fan a close to air tight casing, wet room applications of the fan are possible due to the air tight casing.

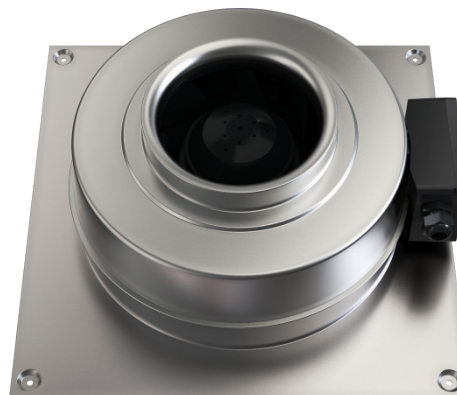

Technical parameters

Nominal data		
Voltage	230	V
Frequency	50	Hz
Phase	1	~
Input power (P1)	148	W
Current	0,648	A
Max. airflow	0,273	m³/s
R.p.m.	2556	r.p.m.
Capacitor	3,5	µF
Weight	4,6	kg
Temperature data		
Max. temperature of transported air	70	°C
Max. temperature of transported air when speed-controlled	70	°C
Sound data		
Sound pressure level at 3 m	46,9	dB(A)

Get In Touch

Call: [0845 6880112](tel:08456880112)
 Email: info@adremit.co.uk

Our Address

Puravent, Adremit Limited, Unit 5a, Commercial Yard,
 Settle, North Yorkshire, BD24 9RH



Protection / Classification

Insulation class	F
Enclosure class, motor	IP44

ErP

ErP ready	ErP 2018
-----------	----------

Diagrams

Diagrams

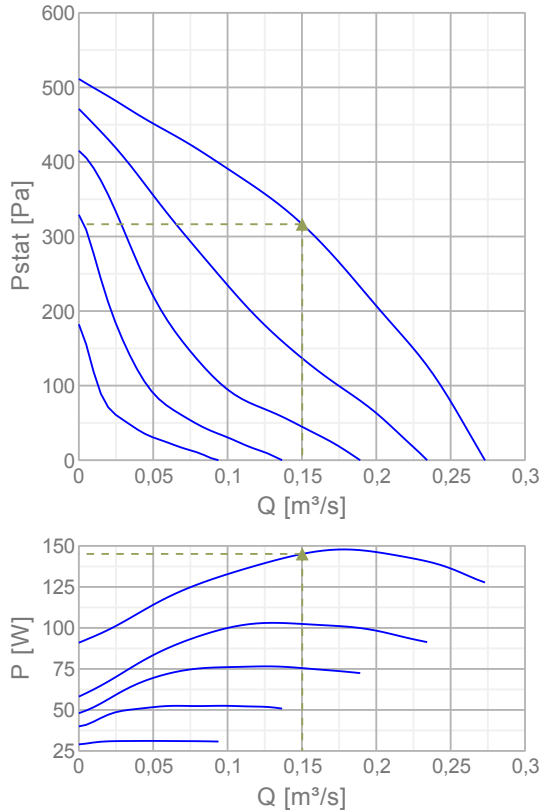

Max efficiency

Hydraulic data										
▲ Working air flow	0,15 m³/s									
▲ Working static pressure	316 Pa									
▲ Power	145 W									
Speed	2564 r.p.m.									
Current	0,635 A									
SFP	0,966 W/(l/s)									
Voltage	230 V									
Sound power level		63	125	250	500	1k	2k	4k	8k	Tot
Inlet	dB(A)	51	56	65	60	63	58	54	49	69
Outlet	dB(A)	34	42	59	62	67	65	55	51	71
Surrounding	dB(A)	38	25	37	47	52	45	39	29	54

Name: **KV 250 L SILEO** | Item no.: **19519** | Version: **50 Hz**

Document type: **Product card** | Document date: **2019-07-10** | Generated by: **Online catalogue**

2 / 5

Get In Touch

Call: [0845 6880112](tel:08456880112)
 Email: info@adremit.co.uk

Our Address

Puravent, Adremit Limited, Unit 5a, Commercial Yard,
 Settle, North Yorkshire, BD24 9RH

Dimensions

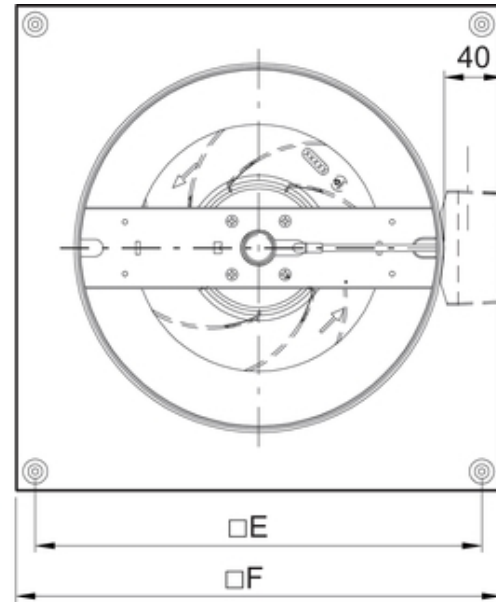
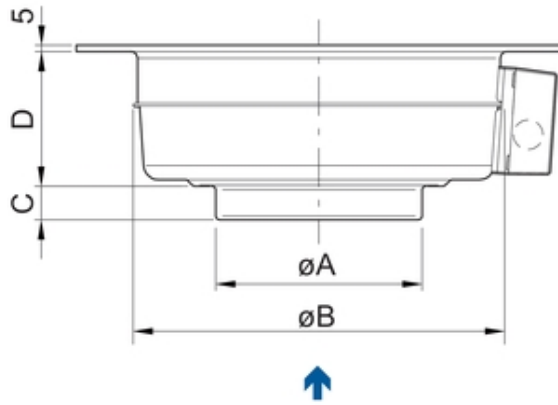

	øA	øB	C	D	□E	□F
KV 250	249	336	30,5	159	394	425

Get In Touch



Call: [0845 6880112](tel:08456880112)



Email: info@adremit.co.uk

Our Address

Puravent, Adremit Limited, Unit 5a, Commercial Yard,
Settle, North Yorkshire, BD24 9RH

230V 1~

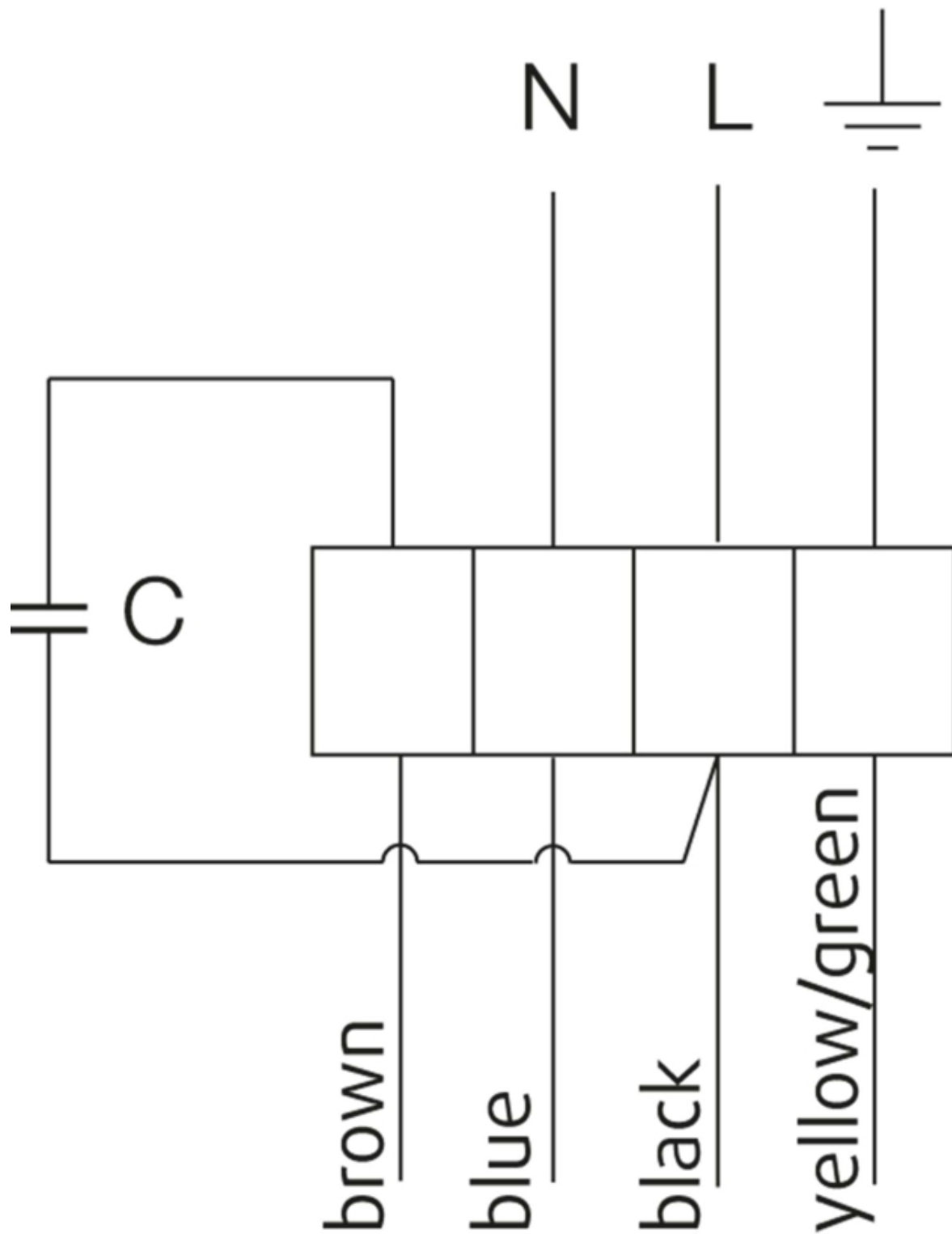

U1 = blue = blau
U2 = black = schwarz
Z = brown = braun
PE = yellow/green = grün-gelb

Get In Touch

Call: [0845 6880112](tel:08456880112)
Email: info@adremit.co.uk

Our Address

Puravent, Adremit Limited, Unit 5a, Commercial Yard,
Settle, North Yorkshire, BD24 9RH

Accessories

Electric accessories

[RE 1.5 Speed control \(5000\)](#)
[REU 1.5 Speed control \(5004\)](#)
[REE 1 Speed control \(5314\)](#)
[REPT 6 Digital regulator \(5698\)](#)
[RT 0-30 Room Thermostat \(5151\)](#)
[CO2RT-R-D Transmitter \(6993\)](#)
[Presence detector/IR24-P \(6995\)](#)
[DTV200 \(6261\)](#)
[STL 1.5 Speed controller \(84251\)](#)
[REV-3POL/03 ON/OFF \(33978\)](#)
[DTV500A \(96807\)](#)

Accessories

[CWK 250-3-2.5 Duct cooler,circ \(30024\)](#)
[VBC 250-2 Water heating batt \(5460\)](#)
[LDC 250-900 Silencer \(5196\)](#)
[FFR 250 Filter cassette \(1776\)](#)
[FGR 250 Filter cassette \(1815\)](#)
[FK 250 Fast clamp \(1612\)](#)
[VKK-250 Back draft damper \(1627\)](#)
[RSK-250 Back draft damper \(5603\)](#)
[SG 250 Protection guard \(5610\)](#)
[VK-35 Louvre shutter \(5642\)](#)
[CBM 250-6.0 400V/2 Duct heater \(9089\)](#)
[VBC 250-3 Water heating batt \(9843\)](#)

Documentation



[202341_Fans_Instructions_CE_A010.pdf \(1,83MB\)](#)

Specification text

KV 250L TW Circular duct fan
DN250, 230V50Hz, 1~, imp. backw. curved

Circular duct fan for wall mounting, easy and direct installation in ducts.
Galvanized sheet steel housing.
Circular connection spigot, length 25mm, acc. to EN1506:1997

Free-running, backward curved centrifugal impeller made of plastic.
Balancing made to G 6.3, motor compl. with impeller statically and dynamically balanced in two planes acc. to DIN ISO 1940 T.1.

Voltage controllable external rotor motor, maintenance-free, the motor is placed inside the air flow for cooling. Integral thermal contacts with manual reset acc. to EN 60335-2-80, speed-controlled via a 5-step transformer or a stepless thyristor. Silent, long-life ball bearings. Terminal box (IP55) on the casing.

Mounting brackets included in delivery.

For indoor, outdoor installation as well as in wet areas.
Air leakage class C acc. to EN 12237:2003.
Installation in any mounting position.

PRODUCT: SYSTEMAIR
TYPE: KV 250L TW
Item no. 1218

Get In Touch



Call: [0845 6880112](tel:08456880112)



Email: info@adremit.co.uk

Our Address

Puravent, Adremit Limited, Unit 5a, Commercial Yard,
Settle, North Yorkshire, BD24 9RH