



# KV 200 L SILEO

Item no. 19518

Version: 50 Hz



## Description

- Speed-controllable
- Quiet-running
- Increased efficiency
- Integral thermal contacts
- Can be installed in any position - duct or wall mounted
- Can be installed outdoors
- Maintenance-free and reliable

The KV sileo series is designed for installation in ducts. All KV-fans have minimum 25 mm long spigot connections. The FK mounting clamp facilitates easy installation and removal, and prevents the transfer of vibration to the duct. The fans have backward-curved blades and external rotor motors. KV sileo fans can be speed-controlled via a stepless thyristor or a 5-step transformer.

To protect the motor from overheating the fan has integral thermal contacts with manual reset.

The casing is manufactured from galvanised sheet steel and folded which gives the fan a close to air tight casing, wet room applications of the fan are possible due to the air tight casing.

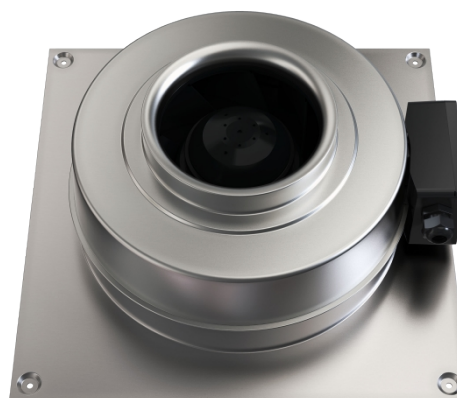

## Technical parameters

Nominal data		
Voltage	230	V
Frequency	50	Hz
Phase	1	~
Input power (P1)	143	W
Current	0,628	A
Max. airflow	0,272	m³/s
R.p.m.	2554	r.p.m.
Capacitor	3,5	µF
Weight	4,5	kg
Temperature data		
Max. temperature of transported air	70	°C
Max. temperature of transported air when speed-controlled	70	°C
Sound data		
Sound pressure level at 3 m	49	dB(A)

### Get In Touch

Call: [0845 6880112](tel:08456880112)  
 Email: [info@adremit.co.uk](mailto:info@adremit.co.uk)

### Our Address

Puravent, Adremit Limited, Unit 5a, Commercial Yard,  
 Settle, North Yorkshire, BD24 9RH



### Protection / Classification

Insulation class	F
Enclosure class, motor	IP44

### ErP

ErP ready	ErP 2018
-----------	----------

## Diagrams

### Diagrams

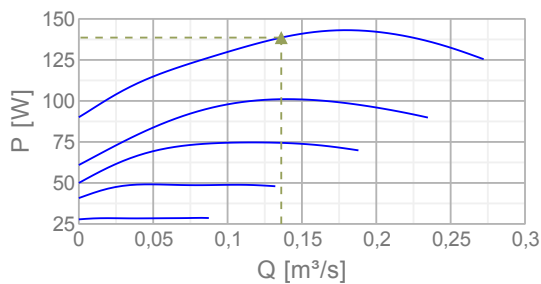
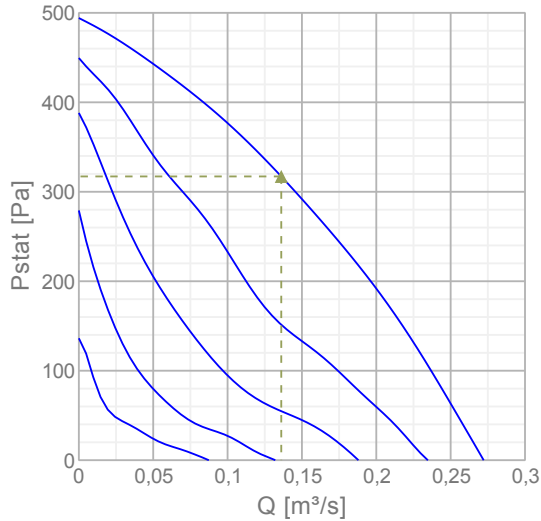

### Max efficiency

Hydraulic data										
▲ Working air flow	0,136 m³/s									
▲ Working static pressure	317 Pa									
▲ Power	139 W									
Speed	2571 r.p.m.									
Current	0,612 A									
SFP	1,02 W/(l/s)									
Voltage	230 V									
Sound power level		63	125	250	500	1k	2k	4k	8k	Tot
Inlet	dB(A)	49	55	64	61	64	62	55	54	69
Outlet	dB(A)	36	46	58	65	67	66	61	55	72
Surrounding	dB(A)	31	29	40	49	51	52	43	36	56

Name: **KV 200 L SILEO** | Item no.: **19518** | Version: **50 Hz**

Document type: **Product card** | Document date: **2019-07-10** | Generated by: **Online catalogue**

2 / 5

### Get In Touch

Call: [0845 6880112](tel:08456880112)  
 Email: [info@adremit.co.uk](mailto:info@adremit.co.uk)

### Our Address

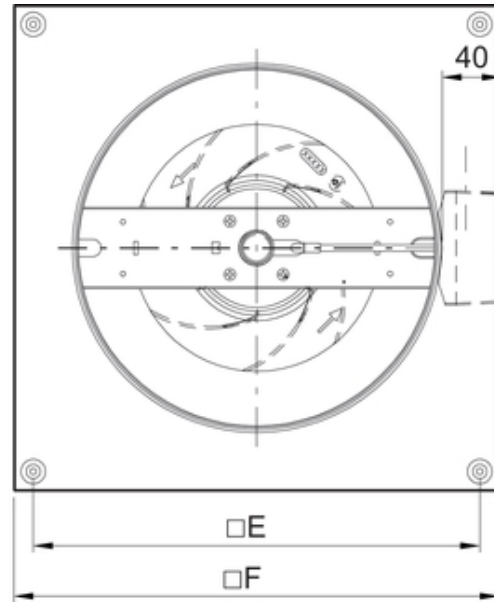
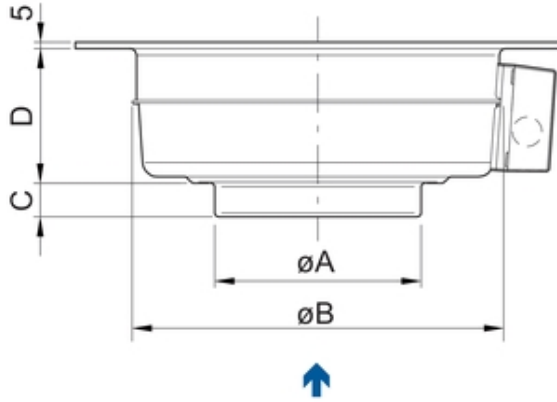

Puravent, Adremit Limited, Unit 5a, Commercial Yard,  
 Settle, North Yorkshire, BD24 9RH

## Dimensions



	øA	øB	C	D	E	F
<b>KV 200</b>	199	336	30	158	394	425

### Get In Touch

 Call: [0845 6880112](tel:08456880112)  
 Email: [info@adremit.co.uk](mailto:info@adremit.co.uk)

### Our Address

Puravent, Adremit Limited, Unit 5a, Commercial Yard,  
 Settle, North Yorkshire, BD24 9RH

230V 1~

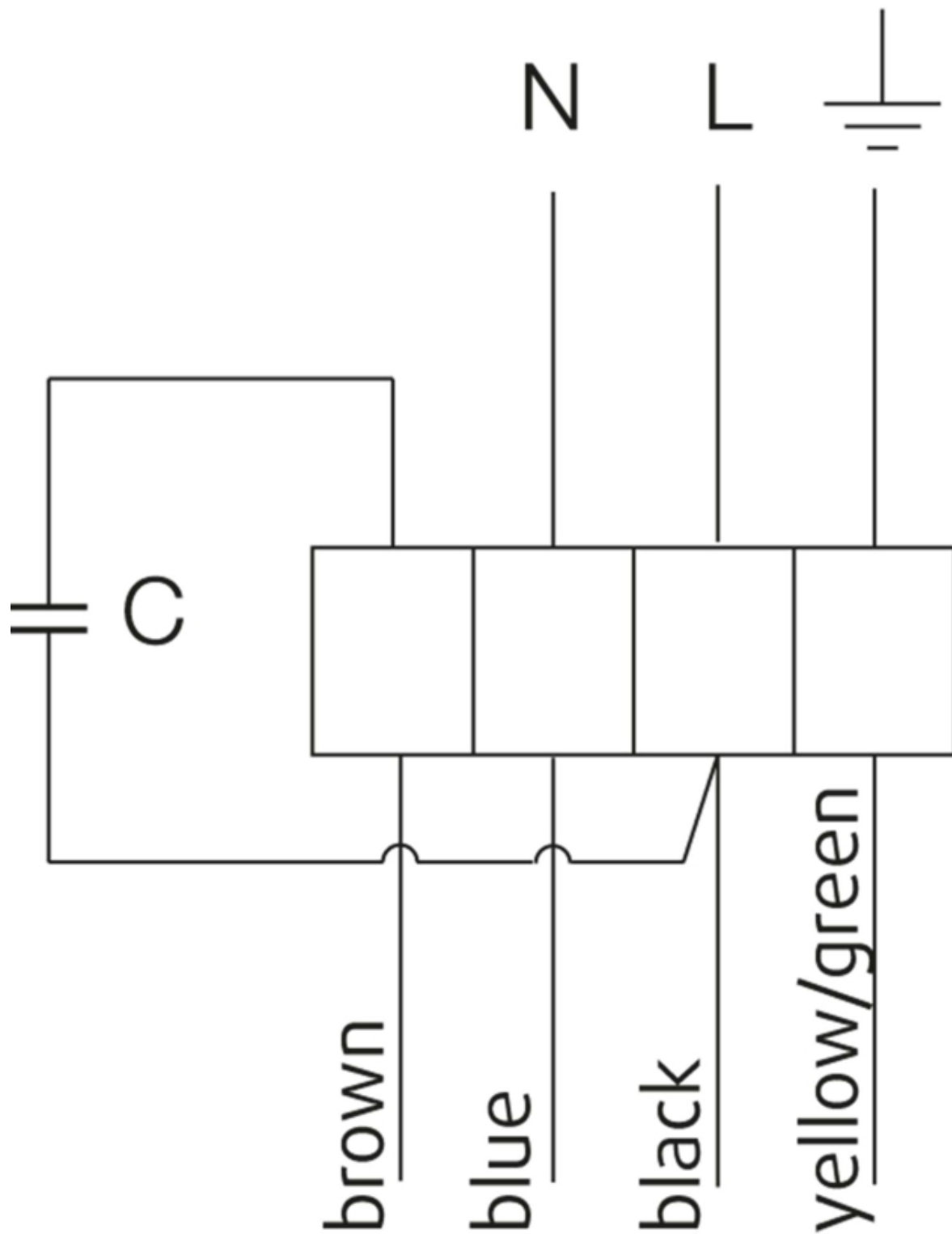

U1 = blue = blau  
U2 = black = schwarz  
Z = brown = braun  
PE = yellow/green = grün-gelb

### Get In Touch

 **Call:** [0845 6880112](tel:08456880112)  
 **Email:** [info@adremit.co.uk](mailto:info@adremit.co.uk)

### Our Address

Puravent, Adremit Limited, Unit 5a, Commercial Yard,  
Settle, North Yorkshire, BD24 9RH

## Accessories

### Electric accessories

[RE 1.5 Speed control \(5000\)](#)  
[REU 1.5 Speed control \(5004\)](#)  
[REE 1 Speed control \(5314\)](#)  
[REPT 6 Digital regulator \(5698\)](#)  
[RT 0-30 Room Thermostat \(5151\)](#)  
[CO2RT-R-D Transmitter \(6993\)](#)  
[Presence detector/IR24-P \(6995\)](#)  
[DTV200 \(6261\)](#)  
[STL 1.5 Speed controller \(84251\)](#)  
[REV-3POL/03 ON/OFF \(33978\)](#)  
[DTV500A \(96807\)](#)

### Accessories

[CBM 200-5,0 400V/2 Duct heater \(5483\)](#)  
[CWK 200-3-2,5 Duct cooler circ \(30023\)](#)  
[VBC 200-2 Water heating batt \(5459\)](#)  
[LDC 200-600 Silencer \(5194\)](#)  
[LDC 200-900 Silencer \(5195\)](#)  
[FFR 200 Filter cassette \(1773\)](#)  
[FGR 200 Filter cassette \(1812\)](#)  
[FK 200 Fast clamp \(1611\)](#)  
[VKK-200 Back draft damper \(1626\)](#)  
[IGK-200 Wall Grid \(1633\)](#)  
[RSK-200 Back draft damper \(5602\)](#)  
[SG 200 Protection guard \(5609\)](#)  
[VK-35 Louvre shutter \(5642\)](#)  
[VBC 200-3 Water heating batt \(9841\)](#)  
[LDC 200-300 Silencer \(53369\)](#)

## Documentation

 [202341\\_Fans\\_Instructions\\_CE\\_A010.pdf \(1,83MB\)](#)

## Specification text

KV 200L TW Circular duct fan  
DN200, 230V50Hz, 1~, imp. backw. curved

Circular duct fan for wall mounting, easy and direct installation in ducts.  
Galvanized sheet steel housing.  
Circular connection spigot, length 25mm, acc. to EN1506:1997

Free-running, backward curved centrifugal impeller made of plastic.  
Balancing made to G 6.3, motor compl. with impeller statically and dynamically balanced in two planes acc. to DIN ISO 1940 T.1.



Voltage controllable external rotor motor, maintenance-free, the motor is placed inside the air flow for cooling. Integral thermal contacts with manual reset acc. to EN 60335-2-80, speed-controlled via a 5-step transformer or a stepless thyristor. Silent, long-life ball bearings. Terminal box (IP55) on the casing.

Mounting brackets included in delivery.

For indoor, outdoor installation as well as in wet areas.  
Air leakage class C acc. to EN 12237:2003.  
Installation in any mounting position.

PRODUCT: SYSTEMAIR  
TYPE: KV 200L TW  
Item no. 1216

## Get In Touch

 **Call:** [0845 6880112](tel:08456880112)  
 **Email:** [info@adremit.co.uk](mailto:info@adremit.co.uk)

## Our Address

Puravent, Adremit Limited, Unit 5a, Commercial Yard,  
Settle, North Yorkshire, BD24 9RH