



KVK DUO 315L**

Item no. 93297

Document type: **Product card**
 Document date: **2019-07-10**
 Generated by: **Systemair Online Catalogue**

Description

- Speed-controllable
- Integral thermal contacts
- Low noise level
- Twin fan

KVK DUO models have double inlet centrifugal fans with forward-curved impellers and maintenance-free external rotor motors. To protect the motors from overheating the fans have integral thermal contacts with leads for connection to a motor protection device.

The fans are easy to connect to spiral ducts using FK mounting clamps.

The KVK DUO models are manufactured from galvanised sheet steel and are thermally and acoustically insulated with a 50 mm layer of mineral wool. Internal surfaces are protected with perforated galvanised sheet steel.



Technical parameters

Nominal data		
Voltage	230	V
Frequency	50	Hz
Phase	1	~
Input power (P1)	448	W
Current	1,96	A
Max. airflow	0,643	m³/s
R.p.m.	1072	r.p.m.
Capacitor	14	µF
Weight	68,2	kg
Temperature data		
Max. temperature of transported air	49,2	°C
Max. temperature of transported air when speed-controlled	49,2	°C
Sound data		
Sound pressure level at 3 m	38,4	dB(A)
Protection / Classification		
Insulation class	B	
Enclosure class, motor	IP22	

Get In Touch

Call: [0845 6880112](tel:08456880112)
 Email: info@adremit.co.uk

Our Address

Puravent, Adremit Limited, Unit 5a, Commercial Yard,
 Settle, North Yorkshire, BD24 9RH

Diagrams

Diagrams

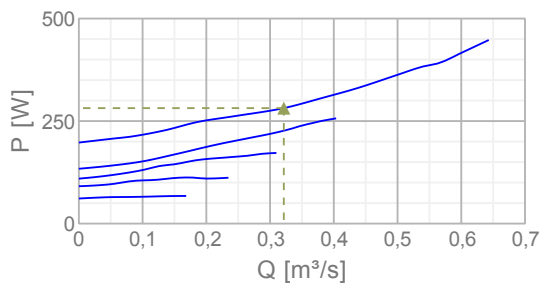
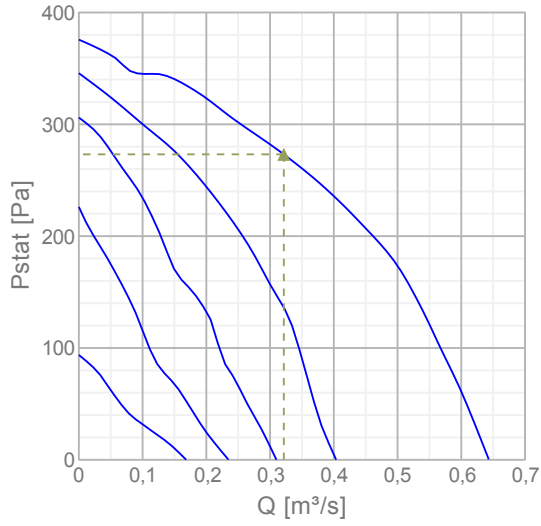

Max efficiency

Hydraulic data										
▲ Working air flow	0,322 m³/s									
▲ Working static pressure	273 Pa									
▲ Power	282 W									
Speed	1357 r.p.m.									
Current	1,31 A									
SFP	0,876 W/(l/s)									
Voltage	230 V									
Sound power level		63	125	250	500	1k	2k	4k	8k	Tot
Inlet	dB(A)	49	60	52	44	45	44	44	41	61
Outlet	dB(A)	56	64	60	64	66	64	61	56	72
Surrounding	dB(A)	27	42	39	37	34	32	32	26	45

Name: **KVK DUO 315L**** | Item no.: **93297**

2 / 5

Document type: **Product card** | Document date: **2019-07-10** | Generated by: **Online catalogue**

Get In Touch

 **Call:** [0845 6880112](tel:08456880112)
 **Email:** info@adremit.co.uk

Our Address

Puravent, Adremit Limited, Unit 5a, Commercial Yard,
Settle, North Yorkshire, BD24 9RH

Dimensions

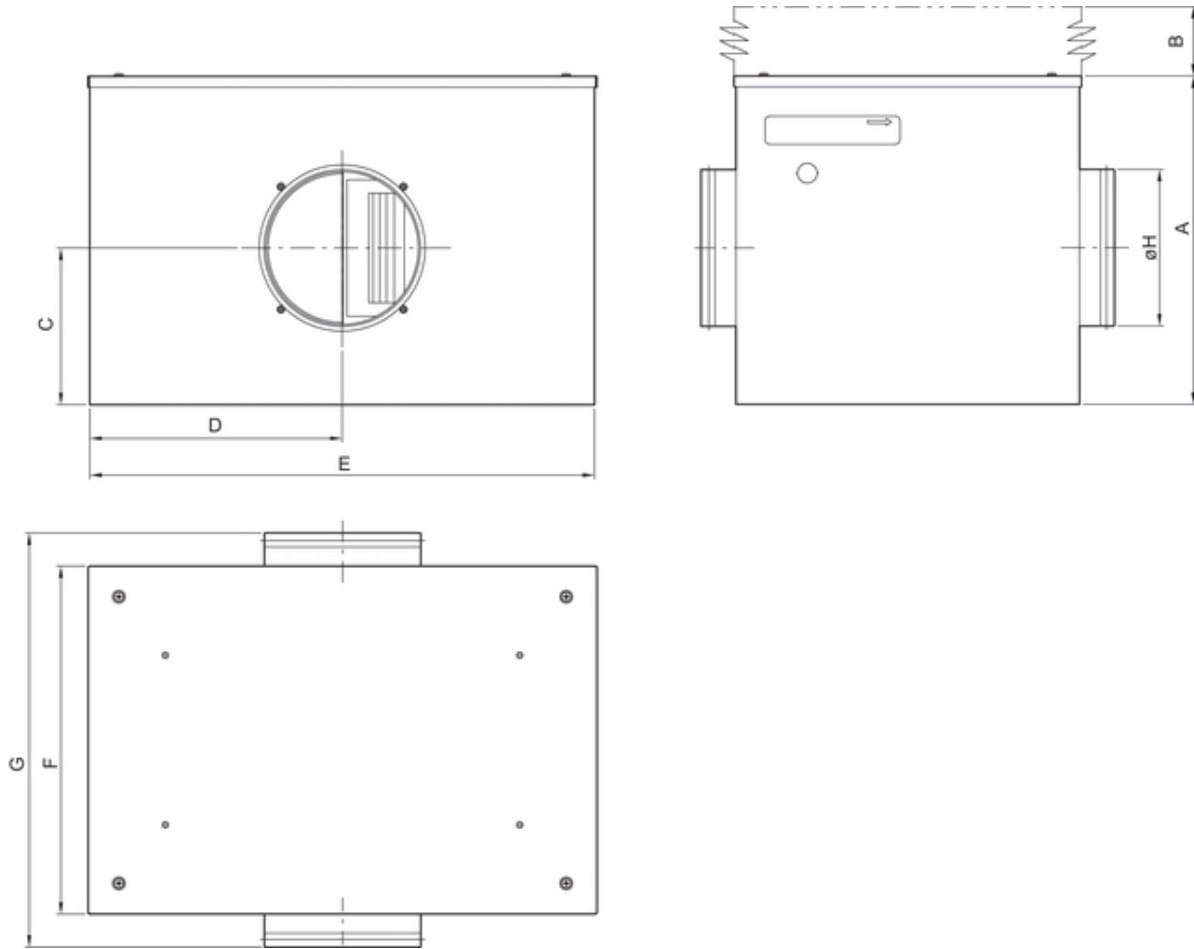



KVK DUO	A	B	C	D	E	F	G	øH
125	333	275	165	255	510	350	425	125
160	333	275	165	255	510	350	425	160
200	386	325	190	300	600	400	475	200
250	460	400	207	360	720	500	615	250
315M	505	450	250	473	946	565	680	315
315L	505	450	250	473	946	565	680	315
355	505	450	250	473	946	565	680	355
400	505	450	250	473	946	565	680	400

Name: **KVK DUO 315L**** | Item no.: **93297**

Document type: **Product card** | Document date: **2019-07-10** | Generated by: **Online catalogue**

3 / 5

Get In Touch

 **Call:** [0845 6880112](tel:08456880112)
 **Email:** info@adremit.co.uk

Our Address

Puravent, Adremit Limited, Unit 5a, Commercial Yard,
Settle, North Yorkshire, BD24 9RH

230V 1~

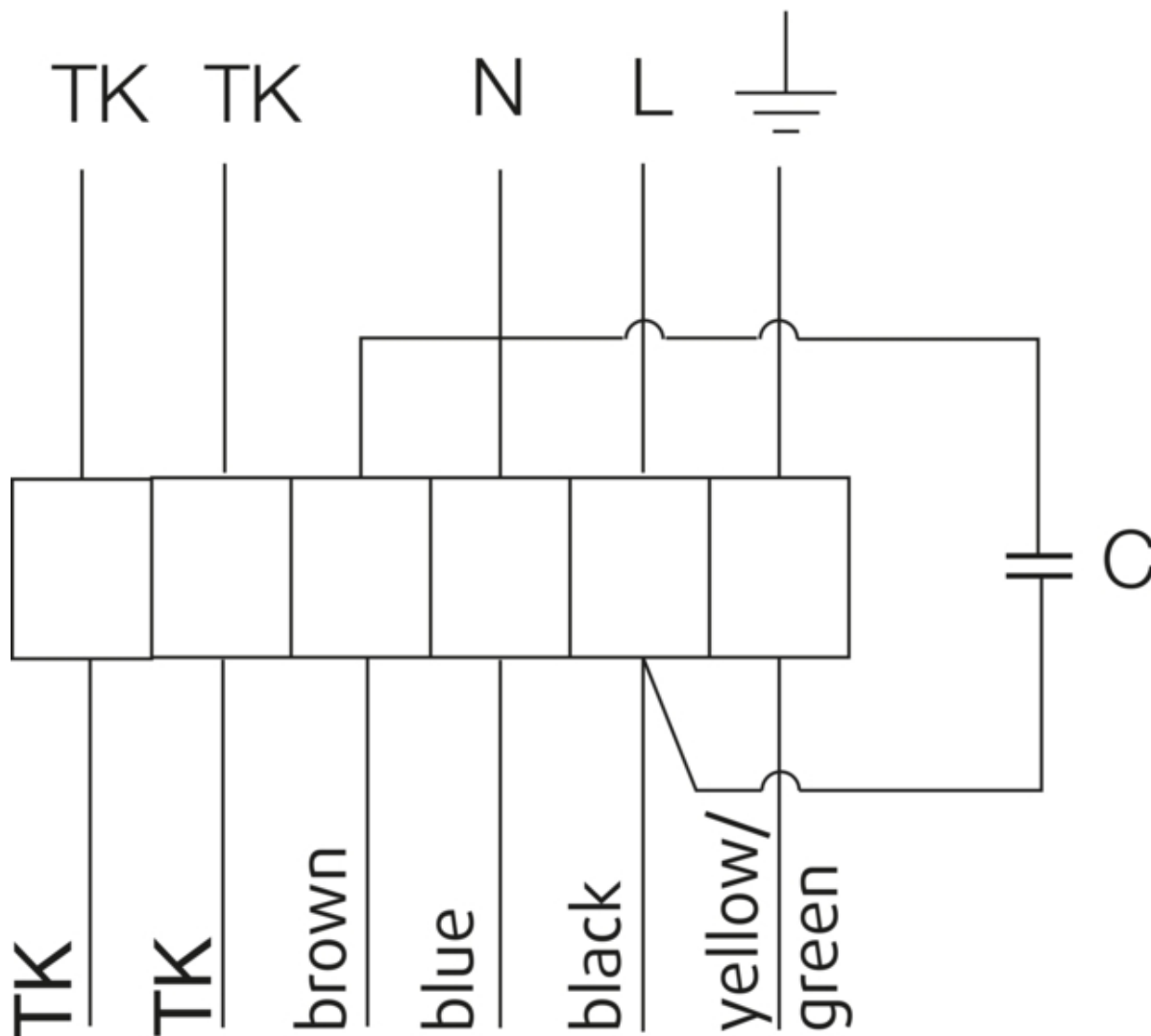

U1 = blue = blau
 U2 = black = schwarz
 Z = brown = braun
 PE = yellow/green = grün-gelb

Accessories

Electric accessories

- [REU 3 Speed control \(5005\)](#)
- [RTRE 3 Speed control \(5009\)](#)
- [REE 4 Speed control \(5317\)](#)
- [S-ET 10 Motor Protection \(5154\)](#)
- [ACO8A Auto Changeover panel \(84291\)](#)
- [STL 5 Speed controller \(84271\)](#)

Get In Touch

Call: [0845 6880112](tel:08456880112)
Email: info@adremit.co.uk

Our Address

Puravent, Adremit Limited, Unit 5a, Commercial Yard,
 Settle, North Yorkshire, BD24 9RH

Accessories

[CB 315-9,0 400V/3 Duct heater \(5375\)](#)
[CB 315-3,0 230V/1 Duct heater \(5386\)](#)
[CB 315-12,0 400V/3 Duct heater \(5387\)](#)
[CBM 315-9,0 400V/3 Duct heater \(5485\)](#)
[VBF 315 Water heating battery \(1734\)](#)
[CWK 315-3-2.5 Duct cooler,circ \(30025\)](#)
[VBC 315-2 Water heating batt \(5461\)](#)
[LDC 315-900 Silencer \(5197\)](#)
[FFR 315 Filter cassette \(1779\)](#)
[FGR 315 Filter cassette \(1818\)](#)
[FK 315 Fast clamp \(1613\)](#)
[VKK-315 Back draft damper \(1628\)](#)
[RSK-315 Back draft damper \(5604\)](#)
[SG 315 Protection quard \(5611\)](#)
[CB 315-6,0 400V/2 Duct heater \(5374\)](#)

Documentation

 [132780_Fans_Instructions_Outside_EU_A002.pdf \(1 006,63kB\)](#)

Specification text

Name: **KVK DUO 315L**** | Item no.: **93297**

Document type: **Product card** | Document date: **2019-07-10** | Generated by: **Online catalogue**

5 / 5

Get In Touch



Call: [0845 6880112](tel:08456880112)



Email: info@adremit.co.uk

Our Address

Puravent, Adremit Limited, Unit 5a, Commercial Yard,
Settle, North Yorkshire, BD24 9RH