



# FXDM14AM FREQUENCY INV. IP54

Item no. 31389

Document type: **Product card**  
 Document date: **2019-07-24**  
 Generated by: **Systemair Online Catalogue**

## Description

frequency inverter with integrated allpole sine filter

Frequency regulator with multifunction display for constant temperature or constant pressure in duct systems with integrated process controller (PID free programmable) or with 0..10V control signal. Two setpoints or manual mode is possible. 2 digital inputs, 2 analog inputs, 1 analog output 0..10V and 2 relais with change-over contact. All in-/outputs are programmable. Total motor protection using thermocontact / thermistor connection. With preprogram modes also for outdoor compensation for easy setup. Menue languages are english, german, swedish,... +24VAC / I<sub>max</sub> 120mA power supply for sensors. Masking up to three settable speed ranges. Min. and max. speed limitation

Integrated allpole sine filter for external rotor motors. Absolute parallel operation of fans, no risk of damage for motor. Screened motor cables are not required!



## Technical parameters

Nominal data		
Voltage range	208-480	V
Phase	3	~
Frequency	50/60	Hz
Max. current	14	A
Recommended fuse	16	A
Permitted max. ambient temperature	40	°C
Enclosure class	IP54	
Weight	8,7	kg

### Get In Touch

Call: [0845 6880112](tel:08456880112)  
 Email: [info@adremit.co.uk](mailto:info@adremit.co.uk)

### Our Address

Puravent, Adremit Limited, Unit 5a, Commercial Yard,  
 Settle, North Yorkshire, BD24 9RH



## Dimensions

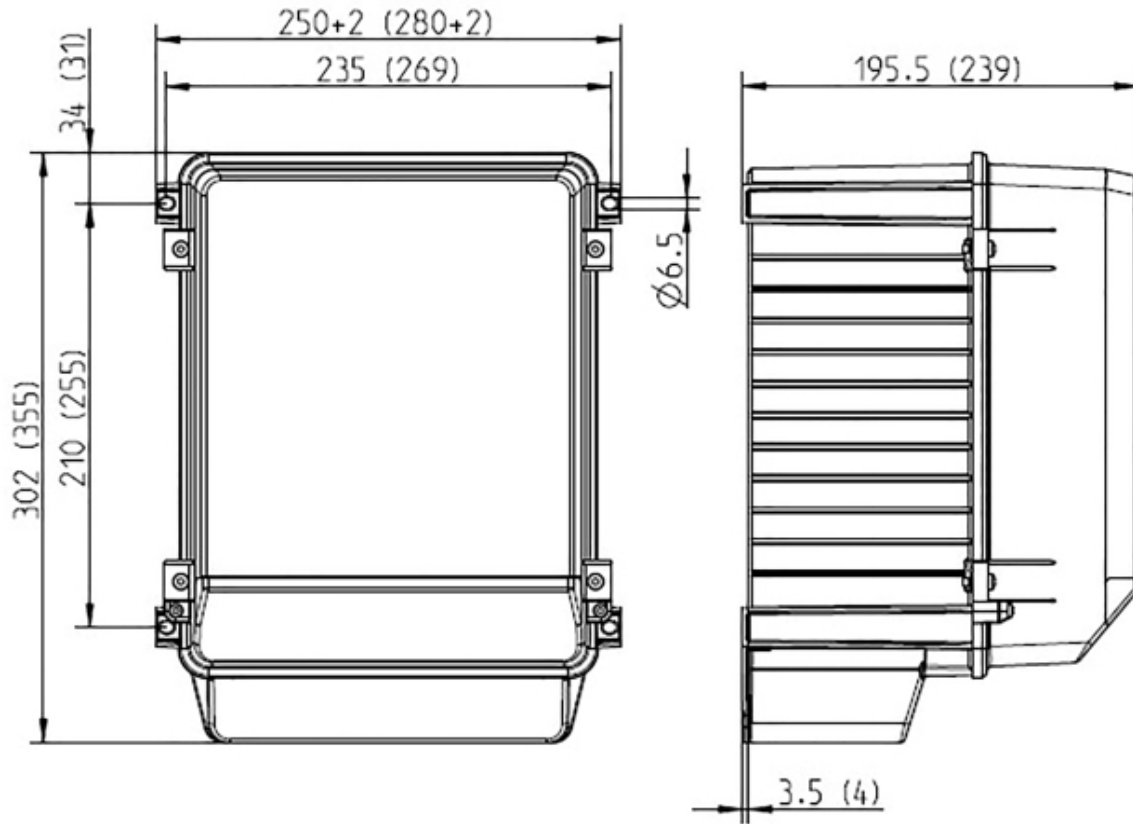

[mm]

FXDM 5 / 8 / 14 / 18 AM (FXDM 22 AM)

## Accessories

### Electric accessories

[TFR Temp. Sensor \(5158\)](#)

[MTV-1/010 Controller 0..10V+ \(30650\)](#)

[MTP 10, 10K, Speed control \(32731\)](#)

[MTP 20, on/off, 3-step \(310220\)](#)

## Documentation

 [L-BAL-E223-GB.pdf \(2,55MB\)](#)

 [L-BAL-E072-GB.pdf \(5,25MB\)](#)

 [Declaration\\_of\\_Conformity\\_FXDM.pdf \(82,80kB\)](#)

Name: **FXDM14AM FREQUENCY INV. IP54** | Item no.: **31389**

Document type: **Product card** | Document date: **2019-07-24** | Generated by: **Online catalogue**

2 / 3

## Get In Touch



Call: [0845 6880112](tel:08456880112)



Email: [info@adremit.co.uk](mailto:info@adremit.co.uk)

## Our Address

Puravent, Adremit Limited, Unit 5a, Commercial Yard,  
Settle, North Yorkshire, BD24 9RH

## Wiring

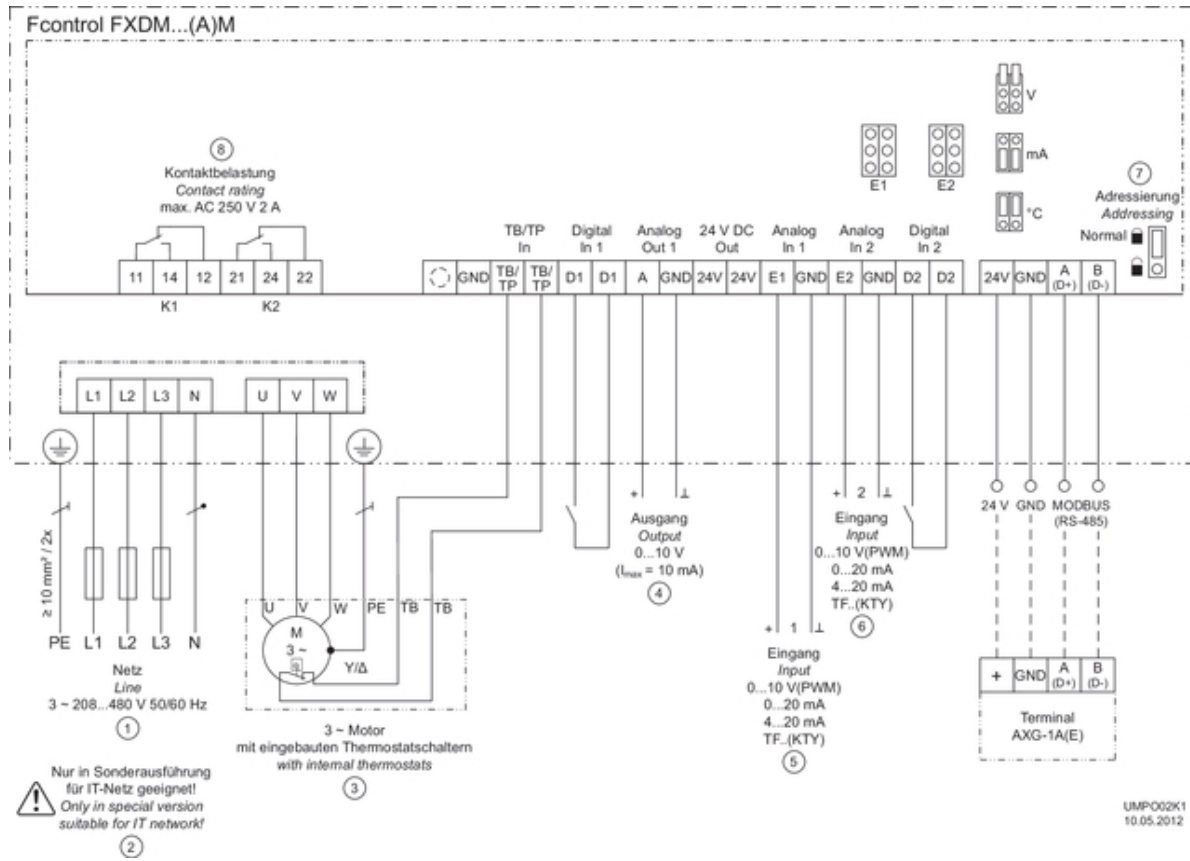

## Specification text

Name: **FXDM14AM FREQUENCY INV. IP54** | Item no.: **31389**

Document type: **Product card** | Document date: **2019-07-24** | Generated by: **Online catalogue**

3 / 3

### Get In Touch

Call: [0845 6880112](tel:08456880112)  
Email: [info@adremit.co.uk](mailto:info@adremit.co.uk)

### Our Address

Puravent, Adremit Limited, Unit 5a, Commercial Yard,  
Settle, North Yorkshire, BD24 9RH