

## DVV Roof Fan

For normal and high temperature air applications + smoke extraction



### Get In Touch



Call: [0845 6880112](tel:08456880112)



Email: [info@adremit.co.uk](mailto:info@adremit.co.uk)

### Our Address

Puravent, Adremit Limited, Unit 5a, Commercial Yard,  
Settle, North Yorkshire, BD24 9RH

# DVV-XS, XM, XL, XP

## Roof Fan for normal ventilation and smoke/heat extract

The octagonal casing is manufactured from seawater resistant aluminium. The base frame is made of hot dip galvanized steel. Galvanized steel (F400), respectively inox (F600) impeller with backward curved blades built-in. Motor cooling with fresh air via air duct. The motor protection to be provided by customers (PTC built-in electric motor). For speed control use only combination of frequency converter and appropriate filter to motor side (sine or du/dt), observing installation conditions (e.g. cable type, length). At frequency controlled units additional EMC protection could be needed (items with EMC protection built-in recommended).



Tested to 400°C/2h (type F400) respectively 600°C/2h (type F600), together with frequency converter. However, we recommend bridging of frequency converter in case of fire to eliminate possible risk of malfunction of frequency converter. In case of fire all motor protective devices and thermal protections in frequency converter must be bridged or disabled to guarantee functional capability.

### Technical data

Motor efficiency class	IE2 (single speed) IE1 (two speed + 8 pole)			IE2 + EMC		IE3 + EMC	
	Item No. DVV/120	Item No. DVV/F400	Item No. DVV/F600	Item No. DVV/120	Item No. DVV/F400	Item No. DVV/120	Item No. DVV/F400
DVV 560D4-XS	95435	95437	95509				
DVV 560D4-XM	95434	95436	95510				
DVV 560D4-XL	95373	95352	95511				
DVV 560D4-6-XL	95414	95413	95512				
DVV 630D4-XS	95321	95306	95513				
DVV 630D6-XL	95320	95305	95514				
DVV 630D4-XL	95318	95303	95515				
DVV 630D4-6-XL	95319	95304	Not available				
DVV 800D6-XS	95327	95312	95517				
DVV 800D4-XS	95326	95311	95518	95482	95489	95438	95444
DVV 800D4-6-XS	95328	95313	95519				
DVV 800D6-XL	95323	95308	95520				
DVV 800D6-8-XL	95325	95310	95544				
DVV 800D4-XL	95322	95307	95521	95483	95488	95439	95445
DVV 800D4-6-XL	95324	95309	95522				
DVV 800D4-8-XL	95395	95394	95543				
DVV 1000D6-XM	95376	95386	95527	95484	95490	95440	95446
DVV 1000D6-8-XM	95377	95387	95528				
DVV 1000D4-XM	95378	95388	95529	95486	95492	95442	95448
DVV 1000D4-6-XM	95379	95389	95530				
DVV 1000D4-8-XM	95375	95396	95531				
DVV 1000D8-XL	95347	95344	95523				
DVV 1000D6-XL	95345	95342	95525	95494	95495	95450	95451
DVV 1000D6-8-XL	95346	95343	95524				
DVV 1000D6-12-XL	95374	95385	95526				
DVV 1000D8-XP	95381	95397	95533				
DVV 1000D6-XP	95382	95390	95532	95485	95491	95441	95447
DVV 1000D4-XP	95383	95391	95534	95487	95493	95443	95449
DVV 1000D4-6-XP	95384	95392	95535				
DVV 1000D4-8-XP	95380	95393	95536				



### Get In Touch

Call: [0845 6880112](tel:08456880112)  
Email: [info@adremit.co.uk](mailto:info@adremit.co.uk)

### Our Address

Puravent, Adremit Limited, Unit 5a, Commercial Yard,  
Settle, North Yorkshire, BD24 9RH

### Type DVV/120-XS, XM, XL, XP



- Normal ventilation up to 120°C continuous operation
- Vertical exhaust, suitable for coastal application
- IE2 single speed high efficiency motor, IE1 two speed or 8-pole motor
- Service switch and PTC thermal protection built-in serial
- Sucking side connection acc. EUROVENT
- Meet ErP efficiency goal

### Type DVV/F400, F600-XS, XM, XL, XP



- Normal ventilation + smoke and heat extract (dual use)
- Type F400 up to 400°C/120 min (F400/120, F400/90, F300, F200)
- Type F600 up to 600°C/120 min (F600, F400/120)
- Tested acc. to EN 12101-3 at ZAG, Ljubljana
- CE-certification acc. to EN 12101-3, 2002-06 by BSI, UK
- Meet ErP efficiency goal for dual use fans
- Other features as DVV/120

### EMC protected items prepared for frequency control

- EMC shielded cable from motor to service switch
- Service switch with capability of connection of shielded power supply cable
- Additional marking "EMC"
- Meet Regulation 640/2009

### Items with IE3 motor built-in

- Meet higher requirements up to 640/2009 regarding motor efficiency

Input power P1 [kW]	Current [A]	Max. airflow [m³/h]	R. p. m. [min⁻¹]	Sound pressure level at 4/10 m [dB(A)]	Weight [kg]*		Wiring diagram	
					IE1, IE2	IE3	no EMC	EMC
1,5 (DVV/120: 1,3)	4,0 (DVV/120: 2,6)	8000	1460 (DVV/120: 1420)	66/59	89		4	
2,2 (DVV/120: 2,0)	4,7 (DVV/120: 3,7)	10150	1442 (DVV/120: 1410)	68/61	91		4	
2,6	5,4	10800	1445	69/62	93		4	
2,7/1,1	5,4/2,3	10800/7250	1445/965	69/62 / 59/52	96		2	
3,7	6,64	15000	1441	71/63	130		4	
2,1	4,5	13600	940	64/58	123		4	
6,4	11	20900	1461	75/69	150		1	
6,9/2,3	11,9/4,6	20900/13600	1445/965	75/69 / 64/58	168		2	
3,8	6,92	20300	932	66/60	224		4	
12,9	22	31500	1461	76/70	260	261	1	5
14,4/4,3	25,1/8,3	31500/20300	1467/965	76/70 / 66/60	291		2	
5,6	11,2	26500	955	71/64	225		1	
6/3	14,8/8	26500/19800	985/736	71/64 / 65/57	297		2	
18,5	34,6	40000	1461	83/75	372	400	1	5
19/5,9	35,4/17,1	40000/26500	1472/988	83/75 / 71/64	401		2	
18,7/3	37/10,6	40000/19800	1470/743	83/75 / 65/57	401		3	
6,5	12,8	32500	980	73/65	366	372	1	5
6,7/3,4	15,8/8,3	32500/25000	981/736	73/65 / 65/57	363		2	
22,3	39	51000	1472	86/78	430	459	1	6
23/7,4	43/19,9	51000/32500	1475/990	86/78 / 73/65	471		2	
24/3,3	39,8/10,4	51000/25000	1484/737	86/78 / 65/57	471		3	
5	10,2	34000	730	66/58	359		1	
11,1	21,4	45000	977	74/66	400	401	1	5
11,1/5,8	21,4/14,1	45000/34000	977/735	74/66 / 66/58	416		2	
11,1/1,7	21,4/5,8	45000/22500	977/488	74/66 / 61/52	416		3	
4,2	8,2	28000	733	67/59	344		1	
9,1	18	37300	982	75/67	388	389	1	5
30,1	51	56000	1473	88/80	499	499	1	6
30,5/9,5	53,5/17,7	56000/37300	1458/987	88/80 / 75/67	519		2	
30,5/4,6	53,5/15,5	56000/28000	1465/740	88/80 / 67/59	494		3	

Due to different motor suppliers the actual motor data and weight can slightly deviate.  
 \* F600 items are app. 5% heavier, exact data are on-line available

Insulation class, motor F; enclosure class, motor IP55

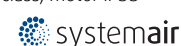

### Get In Touch

Call: 0845 6880112  
 Email: [info@adremit.co.uk](mailto:info@adremit.co.uk)

### Our Address

Puravent, Adremit Limited, Unit 5a, Commercial Yard, Settle, North Yorkshire, BD24 9RH



Performance

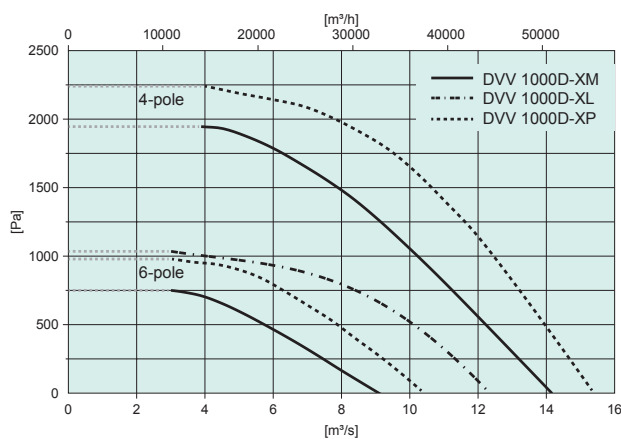
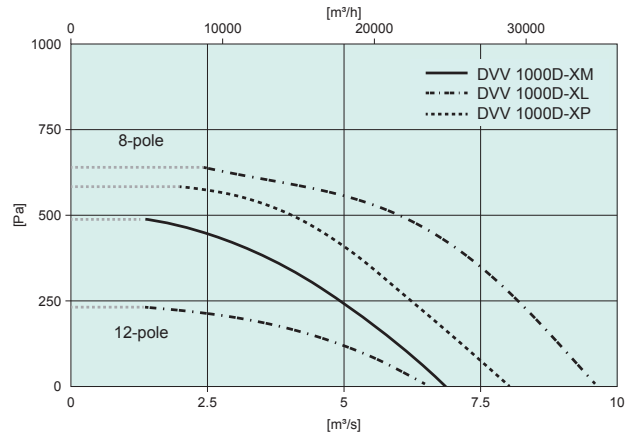
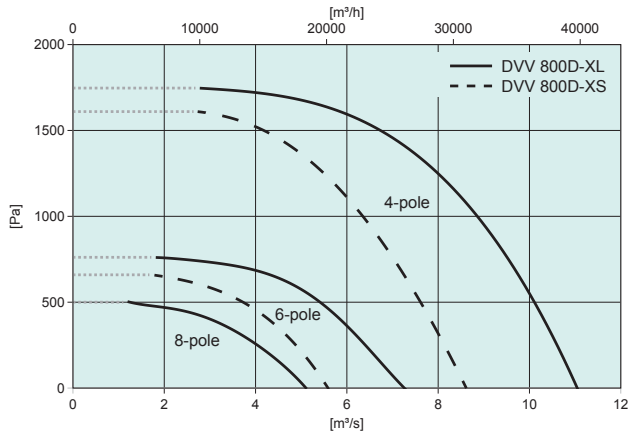
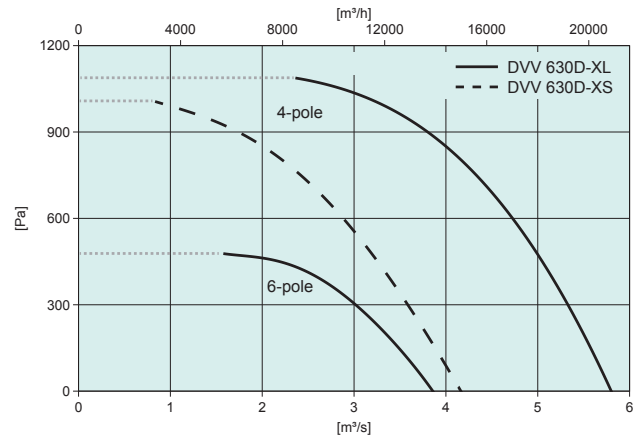
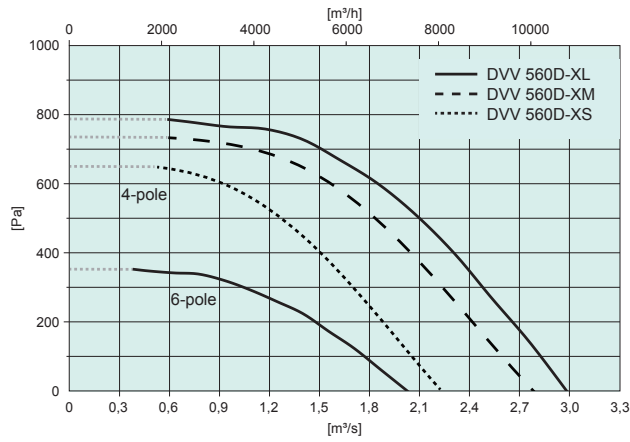

Note: some curves on-line are due to different motors a bit higher than shown here.

..... not applicable area



Get In Touch

Call: 0845 6880112  
 Email: [info@adremit.co.uk](mailto:info@adremit.co.uk)

Our Address

Puravent, Adremit Limited, Unit 5a, Commercial Yard,  
 Settle, North Yorkshire, BD24 9RH



Dimensions

DVV 560

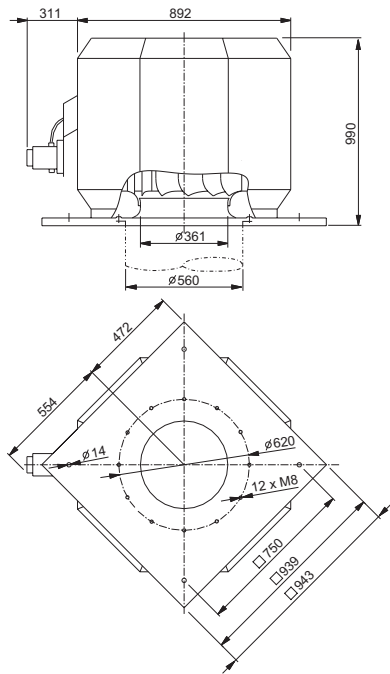

DVV 630

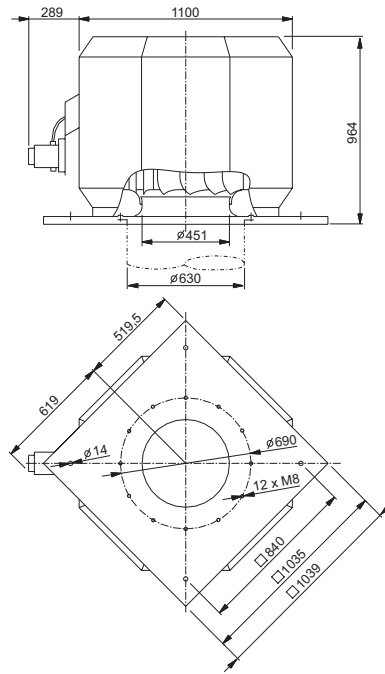

DVV 800D6-XS  
DVV 800D4-XS  
DVV 800D6-XL

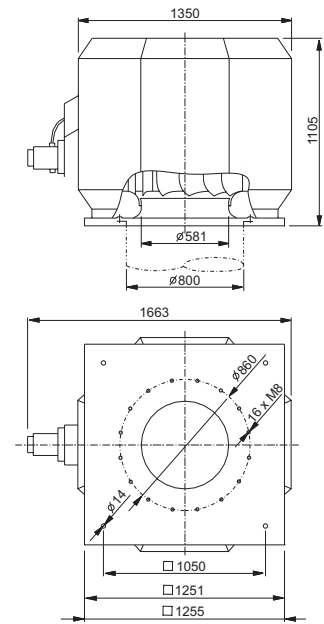

DVV 800D4-6-XS  
DVV 800D6-8-XL  
DVV 800D4-XL  
DVV 800D4-6-XL  
DVV 800D4-8-XL

DVV 1000

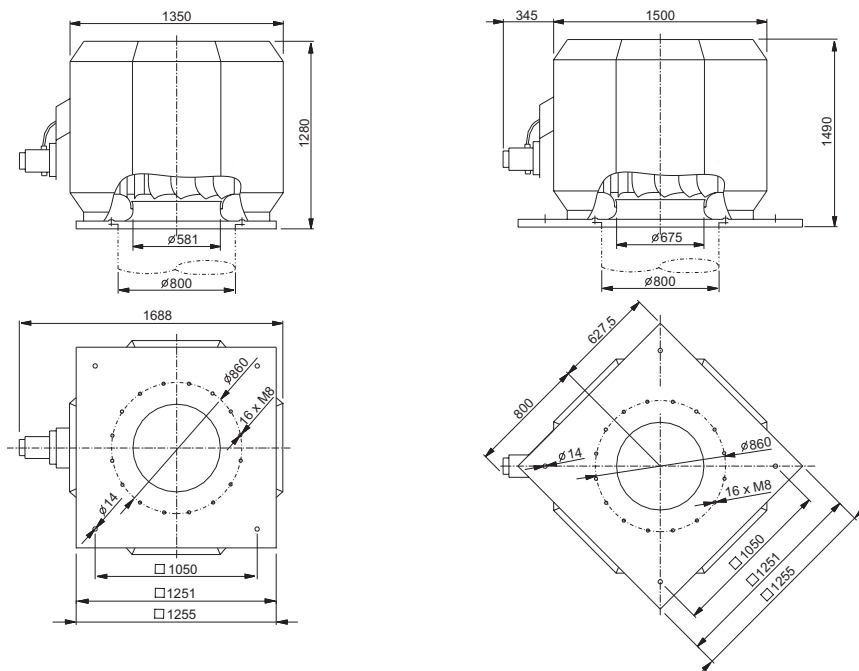

Note: max. dimension of service switch DVV/F600 shown. DVV/F400 and DVV/120, 20~30mm shorter.



Get In Touch

Call: 0845 6880112  
Email: [info@adremit.co.uk](mailto:info@adremit.co.uk)

Our Address

Puravent, Adremit Limited, Unit 5a, Commercial Yard, Settle, North Yorkshire, BD24 9RH



**Wiring diagrams\***

**WD1: wiring D; single speed motor, recommended to start star-delta**

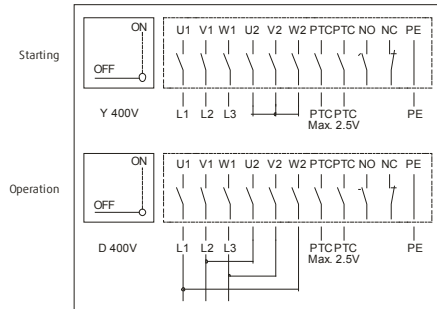

**WD2: wiring Y/Y; two speed motor with separated windings**

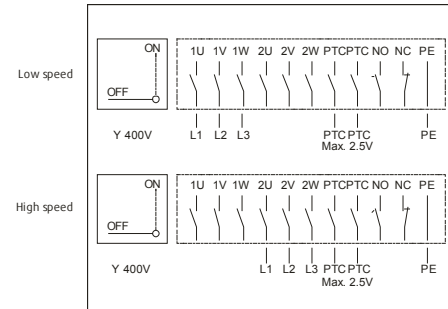

**WD3: wiring YY/Y; two speed motor in Dahlander connection**

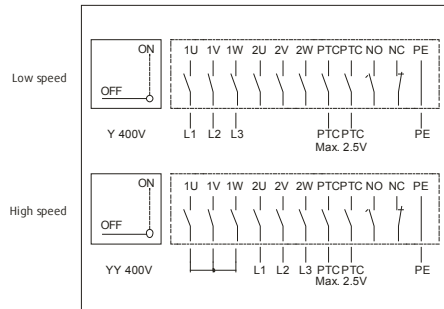

**WD4: wiring Y or D, depending on motor type, prewired inside fan; single speed motor**

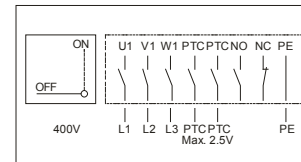

**WD5: single speed motor, prewired in D inside fan, with EMC protection for frequency converter use**

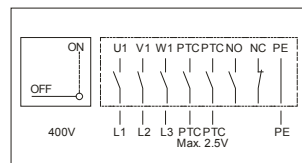

**WD6: wiring D; single speed motor, with EMC protection all wires led out, for frequency converter use**

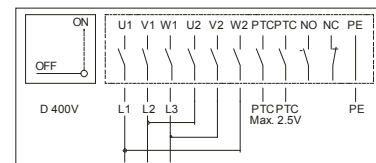

\* Lock in position ON to prevent unintended switch OFF.



Reference: DSV, Kranj, Slovenia

Type of building:  
Global transport and logistics

Products/Solution:  
DVV/F400 Roof Fans for smoke and heat extract, roof sockets, automatic shutters,...



**Get In Touch**

Call: 0845 6880112  
Email: [info@adremit.co.uk](mailto:info@adremit.co.uk)

**Our Address**

Puravent, Adremit Limited, Unit 5a, Commercial Yard, Settle, North Yorkshire, BD24 9RH



**DVV-XS, XL installation examples**

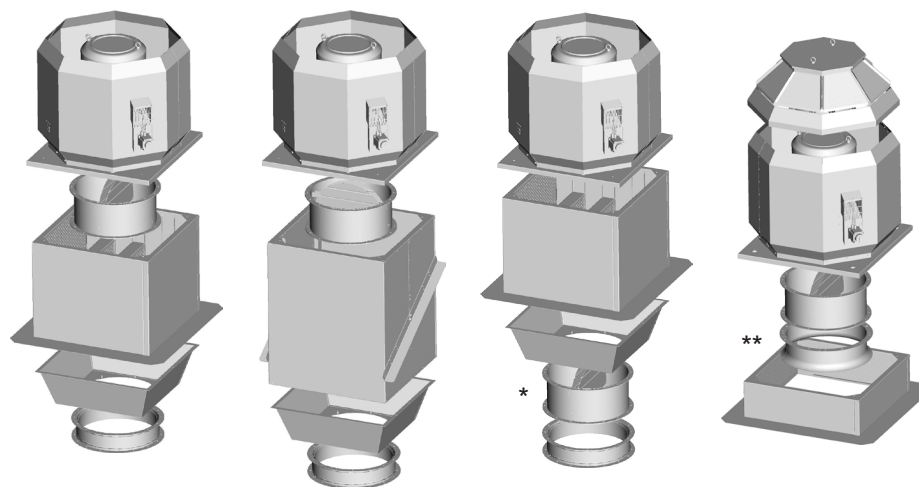

\* Note: if the fan is intended for emergency use only, the shutter below roof base could lead to condensation on the non-insulated base plate of the fan (low air change rate)

\*\* Inlet cone for improving inlet conditions; it is not possible to mount it into socket silencers

**Accessories**

Details of following and electrical accessories are on-line available.

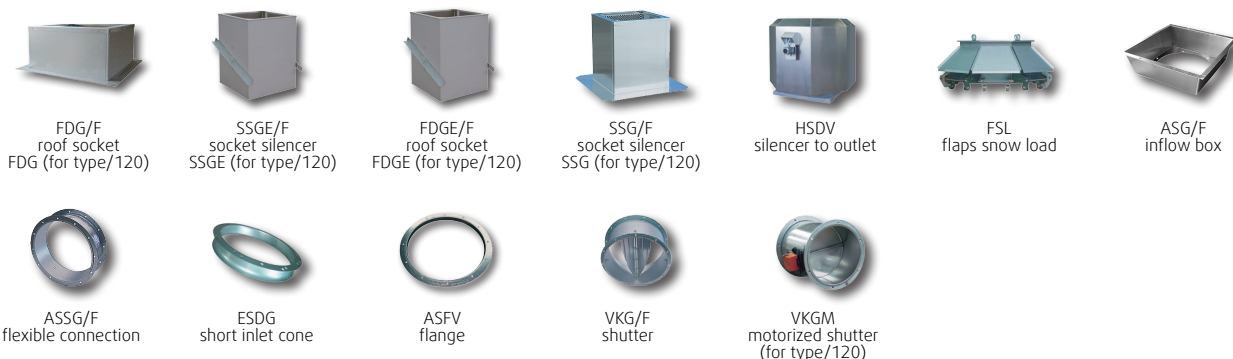

**Ordering key**

**DVV 1000D4-XM/F400**

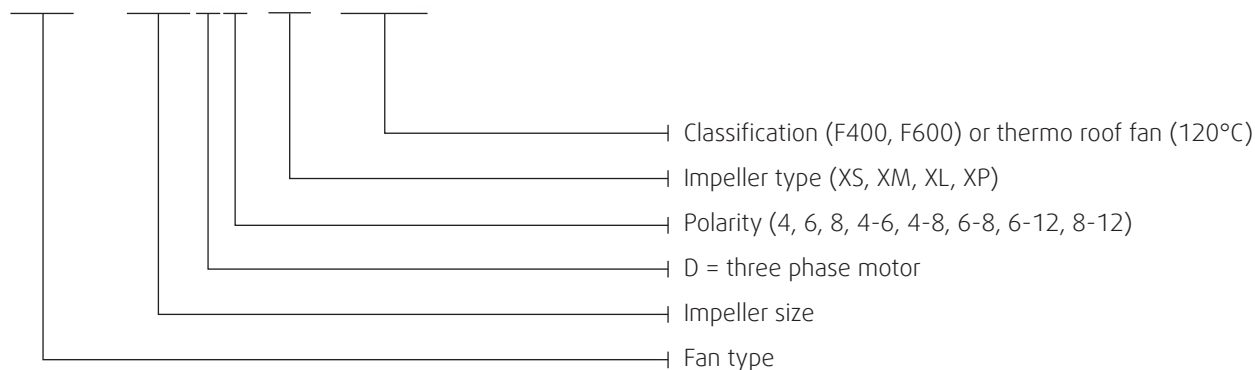

**Get In Touch**

Call: 0845 6880112  
 Email: [info@adremit.co.uk](mailto:info@adremit.co.uk)

**Our Address**

Puravent, Adremit Limited, Unit 5a, Commercial Yard, Settle, North Yorkshire, BD24 9RH





[www.systemair.com](http://www.systemair.com)

Systemair d.o.o. - August 2015 - E8302

#### Get In Touch



Call: [0845 6880112](tel:08456880112)



Email: [info@adremit.co.uk](mailto:info@adremit.co.uk)

#### Our Address

Puravent, Adremit Limited, Unit 5a, Commercial Yard,  
Settle, North Yorkshire, BD24 9RH

