

## DIMENSIONS

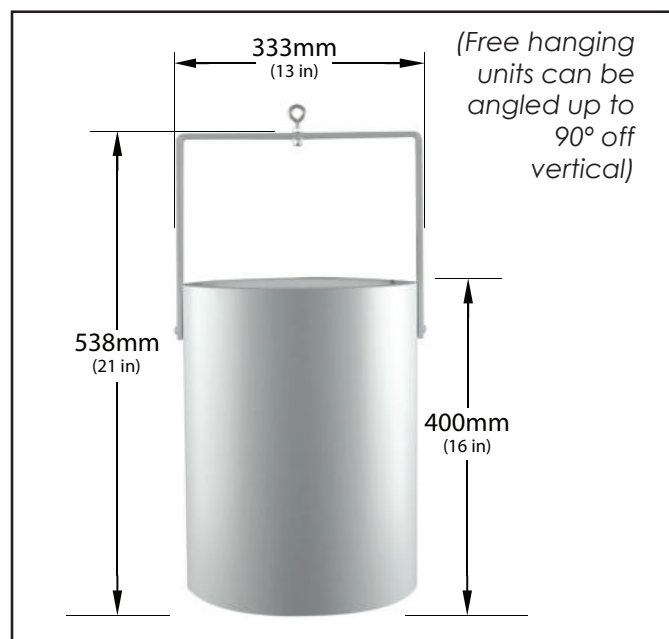

## PROPERTIES

UNIT SIZE	Standard	
	Weight:	6.8 kgs (15 lbs)
	Height to Rim:	400 mm (16 in)
	Total Height:	538 mm (21 in)
Diameter:	333 mm (13 in)	

MOTOR	230V	
	Watts* @ 50 hz:	31
	RPM* @ 50 hz:	1,450
	CFM* @ 50 hz (m3/hr):	459 (780)
	AMPS* @ 50 hz:	0.14

\*Motor data provided by motor manufacturer and is subject to change at anytime

## DESIGNER SERIES RANGE - MODEL 25

### COVERAGE

- Ceiling Height = 6m - 8m (19 - 26 ft)
- Nozzle Height = 6m - 7m (19 - 22 ft)
- Diameter = 11m - 13m (36 - 43 ft)
- Floor area = 89m<sup>2</sup> - 133m<sup>2</sup> (958 - 1,432 ft<sup>2</sup>)

### MOTOR

- Single phase, shaded pole, single speed (variable with optional speed control), axial motor
- Sealed bearings, no lubrication required

### OPERATING TEMPERATURES

- Operating Temp = -20°C (-4°F) to 70°C (158°F)
- Thermal shut off = 110°C (230°F)
- Reset = 90°C (195°F)

### HOUSING

- Aluminium cylindrical housing
- Powder coated
- Internal PC/ABS resin fixed blade stator
- 5VA flame rating



### NOISE LEVEL

- Floor Level = 0 - 31 dB(A)

### INGRESS PROTECTION

- IP55 Rated

### COLOUR

- Cool gray 2C - Off white as standard
- Can be tailor painted to your colour specifications

### ACCESSORIES & OPTIONS

- Speed Controls - On/off speed controls allow for variable output from Airius unit. 1 AMP and 5 AMP controls available

### WARRANTY

- 5 years parts and workmanship from shipping date
- 120 day money back guarantee (T's & C's apply)

Airius Europe Ltd | Holwell Farm, Cranborne, Dorset BH21 5QP | www.airius.co.uk | +44 (0)1202 554200

### Get In Touch

Call: 0845 6880112  
Email: [info@adremit.co.uk](mailto:info@adremit.co.uk)

### Our Address

Puravent, Adremit Limited, Unit 5a, Commercial Yard,  
Settle, North Yorkshire, BD24 9RH

## PROPERTIES

### VELOCITY PROFILE

1.5 m—  
(5 ft)

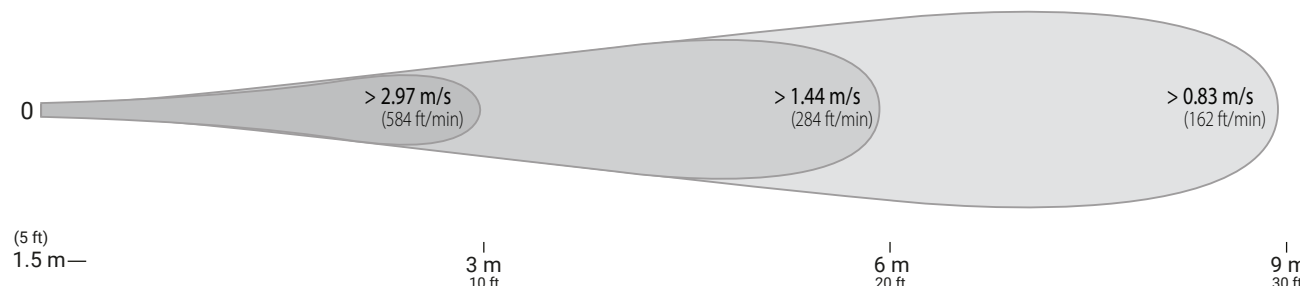

## PLACEMENT

### PREPARATION

- Install electrical circuit(s) and outlet(s) in accordance with national and local electric codes
- Outlets should generally be mounted vertically unless a "twist/locking" type is being used
- Wall switch may be installed in circuit to disable power and prevent electrical hazards when servicing
- Confirm electrical continuity of Airius unit on the ground before permanently mounting in the ceiling

### INSTALLATION

- Hang vertically as high in the ceiling as possible  
Typically 300mm (12") - 450mm (18") from the roof deck to intake
- The Airius unit performs best when air column from the nozzle is unimpeded to the floor
- Use professionally installed hardware, capable of supporting a minimum of five times the weight
- Hardware to hang the unit includes but is not restricted to: Hooks, chains, cables, carabiners, bridle rings, beam clamps and bolts
- Density of the placement is directly related to the effectiveness, performance and savings
- Mount out of reach from people and animals
- Floor plans, mezzanines, office locations, machinery, people placement, plumbing, lighting, duct work, electrical systems, natural light/air systems, cranes, doors, windows, ventilation and fire suppression systems are all factors in properly locating the Airius system within the ceiling

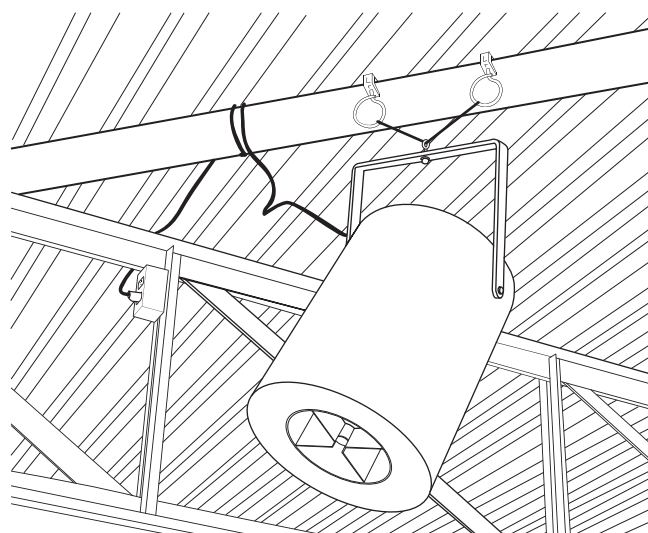

### OPERATION

- Designed to operate 24 hours-a-day, 7 days-a-week to maintain thermal equalization/humidity equalization
- Use optional speed control to fine tune RPM if needed

### MAINTENANCE

- Frequency of cleaning will vary by application and environment
- You may clean the plastic housing with a damp warm cloth, using mild household detergents
- Do not use petroleum products, thinners or solvents to clean any part of the Airius unit
- If the Airius unit fails, contact manufacturer

Airius LLC, © 2011. All Rights Reserved.

Airius Europe Ltd

Holwell Farm, Cranborne, Dorset BH21 5QP

[www.airius.co.uk](http://www.airius.co.uk)

+44 (0)1202 554200

### Get In Touch

Call: 0845 6880112  
Email: [info@adremit.co.uk](mailto:info@adremit.co.uk)

### Our Address

Puravent, Adremit Limited, Unit 5a, Commercial Yard,  
Settle, North Yorkshire, BD24 9RH