



# TRION<sup>®</sup>



Air Purification Systems



## Air Boss<sup>®</sup> T-Series *Electronic Air Cleaners*

Air Purification Systems | [www.trion.co.uk](http://www.trion.co.uk)

### Get In Touch

 Call: [0845 6880112](tel:08456880112)  
 Email: [info@adremit.co.uk](mailto:info@adremit.co.uk)

### Our Address

Puravent, Adremit Limited, Unit 5a, Commercial Yard,  
Settle, North Yorkshire, BD24 9RH



# Engineered Solutions For Clean Air

The Trion® T-Series is ideal for the removal of smoke, fumes, and oil/coolant smoke and mist. The T-Series has the ability to clean contaminated indoor air and recirculate it back to the work area, reducing energy costs by not having to exhaust conditioned air to the outside. Models T1300, T2600 and T5200 can be installed either unducted or ducted for source capture. Models T1001 and T2002 are designed for ducted applications.

## Features

- Ceramic Insulators (stand off)
- Solid State Power Supply
- Spiked Ionising Blades
- Extra Depth Collector Cells
- Totally Enclosed Fan Cooled Motor (Blower Units)
- Electrical Component Box Mounted out of Air Stream
- Modular Approach for Greater Flexibility

## Benefits

- Ceramic Insulators — Out of Airstream for Increased Reliability
- Extra Depth Collector Cell with Greater Dirt Holding/Collection Capacity
- Spiked Ioniser — No Ionising Wires to Replace, Reducing Maintenance: No Consumable Parts
- High Efficiency — up to 95% on Single Pass and 99% on Double Pass Option (DOP Test Method)
- Permanent Ioniser/Collector Elements — No Consumable Filter Cost; Just Wash, Dry and Reinstall
- Low Pressure Drop (90 Pa — Lower Energy Cost to Operate Compared to Media and Cartridge Units)
- Hinged Door Filter Access — Quick & Easy access — No Tools Required

[www.trion.co.uk](http://www.trion.co.uk)



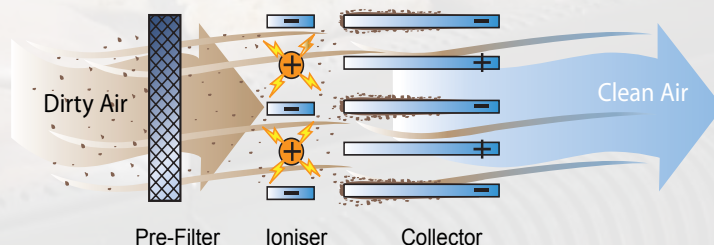

## How it Works

The Trion® T-Series utilizes the principle of Electrostatic Precipitation. Air is drawn by the motor/blower through a washable metal mesh pre-filter which traps large dust particles. The remaining particles, some as small as 0.01 microns, pass into a strong electrical field (ionising section) where the particulate receives an electrical charge. The charged particles then pass into a collector plate section made up of a series of equally spaced parallel plates. Each alternate plate is charged with the same polarity as the particles, which repel, while the interleaving plates are grounded, which attract and collect.



### Get In Touch

 Call: [0845 6880112](tel:08456880112)  
 Email: [info@adremit.co.uk](mailto:info@adremit.co.uk)

### Our Address

Puravent, Adremit Limited, Unit 5a, Commercial Yard,  
Settle, North Yorkshire, BD24 9RH

# Air Boss® T2002 Specifications

## Top View

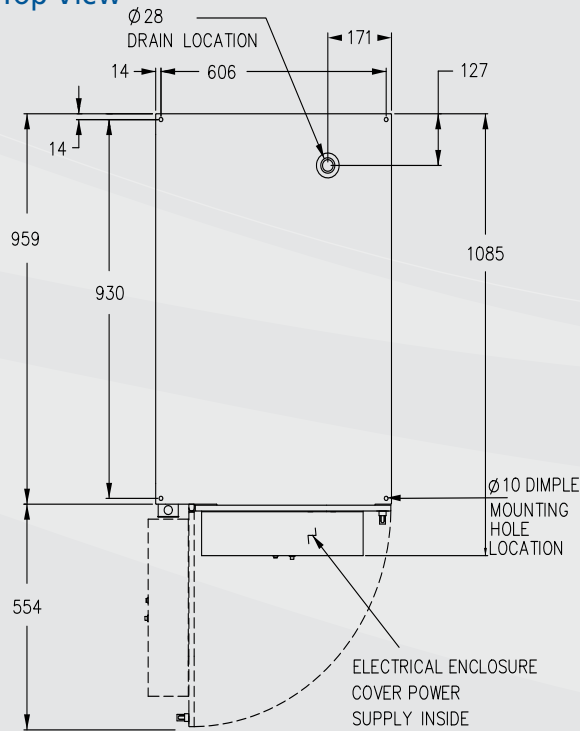

## T2002

<b>Dimensions</b>	635L x 1085W x 533H mm
<b>Installation</b>	Free Standing, Wall or Frame Mounted
<b>Unit Weight</b>	80 kg
<b>Input Voltage</b>	230Vac/1phase/50 Hz
<b>Cell Power</b>	50 watts
<b>Output Voltage</b>	12 kV/6 kV
<b>No of cells</b>	2
<b>Cell Weight</b>	15 kg
<b>Air Volume</b>	up to 4420 m <sup>3</sup> /hr
<b>Controls</b>	On/Off Switch with Indicator
<b>Pre-filter</b>	Aluminum Standard Mesh (2 Req.) (Optional Impinger)
<b>Primary Filter</b>	Electronic Ioniser/Collector Cell
<b>After Filter</b>	Optional Disposable Charcoal After Filter
<b>Power Supply</b>	High Frequency Solid State Design
<b>Efficiency</b>	To 95% Based on D.O.P. Test Method To 99% for Double Pass (Calculated)
<b>General</b>	Multiple Units Can Be Joined Together for Increased Volume Or Efficiency

*Note: Units can be stacked in configurations up to 17680m<sup>3</sup>/hr.  
Multiple Units can be Joined Together For Increased Volume or Efficiency*

## Discharge End

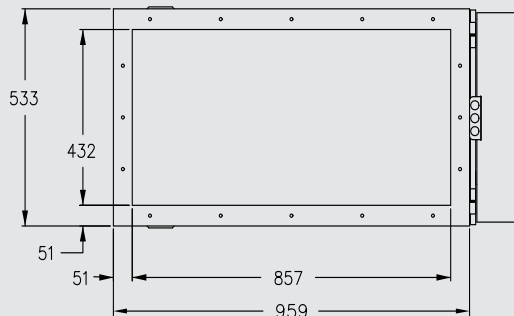

## Front View

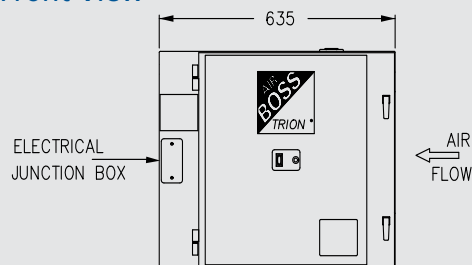

## Intake End

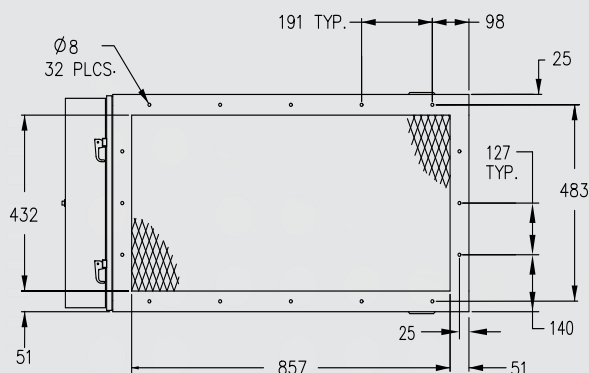

[www.trion.co.uk](http://www.trion.co.uk)

3

## Get In Touch

Call: 0845 6880112  
Email: [info@adremit.co.uk](mailto:info@adremit.co.uk)

## Our Address

Puravent, Adremit Limited, Unit 5a, Commercial Yard,  
Settle, North Yorkshire, BD24 9RH