



# Safety Considerations

Read all instructions before attempting to operate this machine and save these instructions.

**Warning!** When using electric machines, basic safety precautions should always be followed to reduce the risk of fire, electric shock and personal injury, including the following:

**1. Work area environment**

Don't expose the machine for rain. Don't use it in damp or wet locations or in presence of flammable liquids or gases.

**2. Overload**

Never let the machine operate fully throttled. Always follow the regulations pertinent to the material you are working with. Don't use the machine for purposes that it isn't intended for.

**3. Don't abuse cord**

Never pull the machine by cord. Keep cord from heat and sharp edges. Check the electric cable regularly if damage. The cord should not be wrapped around the handle during operation.

**4. Important measure**

With cleaning and maintenance on the machine, the power cable should be disconnected from the supply.

**5. Maintain the machine with care**

Keep the machine clean and check that the hose (extra accessories) is undamaged and that all gaskets are tight. Follow instructions. Keep handles dry and free from oil and grease.

**6. Checking for damage**

Before further use of the machine it should be carefully checked that the machine is undamaged. If there are any damaged parts these should be repaired by a Dustcontrol authorized service center.

**7. Warning**

Use only accessories and replaceable parts which are available in the Dustcontrol catalogue. When using faulty parts or non original parts (especially filter) the machine could leak out unhealthy dust which can cause personal injuries.

## TECHNICAL DATA

HxWxL	380 x 340 x 495 mm
Weight	13 kg
Outlet	φ 125 mm
Hose length (extra accessories)	5-10 m (φ 125)
Flow, at open outlet	500 m <sup>3</sup> /h
Neg pressure	max 400 Pa
Power consumption	230 V, 210 W, 115 V 50/60 Hz 145 W
Degree of separation, EN 1822-1	HEPA 13
Soundlevel*/:	
Speed 1	45 dB(A)
Speed 2	65 dB(A)

\*/ Sound level at 1,6 m height and 1 m distance according to DIN EN ISO 3744 in free space and at maximum airflow.

### Get In Touch

Call: 0845 6880112  
 Email: [info@adremit.co.uk](mailto:info@adremit.co.uk)

### Our Address

Puravent, Adremit Limited, Unit 5a, Commercial Yard, Settle, North Yorkshire, BD24 9RH

## Description

The DC AirCube 500 aircleaner is intended for cleaning the air in a work area and is intended for use as a complement to spot extraction. Air is passed through a combination prefilter and a microfilter. The microfilter is a HEPA 13 filter separates particles to 99.95%. The pre-filter separates the majority of the course particles and thereby prolonging the life of the microfilter.

When a loss of suction capacity is experienced the pre-filter should be changed. If the suction capacity does not increase after the pre-filter change then the Hepa filter should also be changed.

The fan has two speed settings which allow for economical running, for example during the night.

The DC AirCube 500 can also be used to discharge air from work places which must be kept under negative pressure. A 125 mm hose can be attached to the fan outlet where necessary.

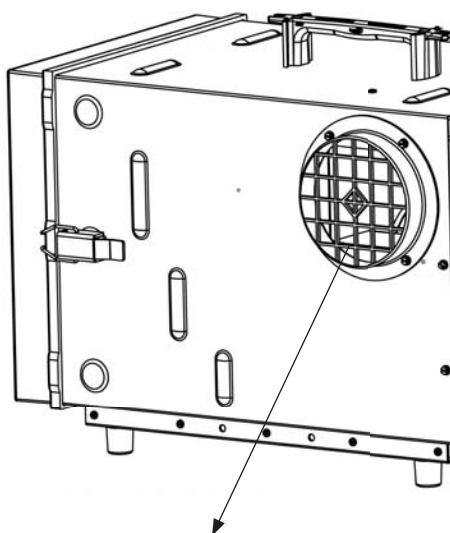

NOTE: When using a long tube or covering the outlet, the warning light (filter light) can be lit.

Check when changing the filter that the outlet is free (warning light).



Optimal power outlet 240 V 1200 W.

## Operation

Connect the machine to a suitable power source according to the specification of the machine. When using an extension cable with the machine, ensure that the connection is water tight and the extension cable is suitably rated.

The DC AirCube 500 aircleaner has two speed settings which allows for economical running, for example during the night.

DC AirCube 500 - 10

Part No 94156

### Get In Touch

Call: [0845 6880112](tel:08456880112)  
Email: [info@adremit.co.uk](mailto:info@adremit.co.uk)

### Our Address

Puravent, Adremit Limited, Unit 5a, Commercial Yard,  
Settle, North Yorkshire, BD24 9RH



# Service

While performing cleaning or maintenance on the machine, the unit should be off and disconnected from the power supply.

When the suction is reduced, due to the filters becoming clogged. The pre-filter should be changed. Turn the "soft" surface out and the "hard" surface towards the HEPA-filter.

If the suction still is weak, the HEPA filter should be changed too. With heavy dust loads the life of the filters are shorter. Use only original spare part filter 4080. Use suitable breathing protection and do the operation in a closed room. The used filter should be sealed in a plastic bag and disposed of according to approved methods.

Montage:

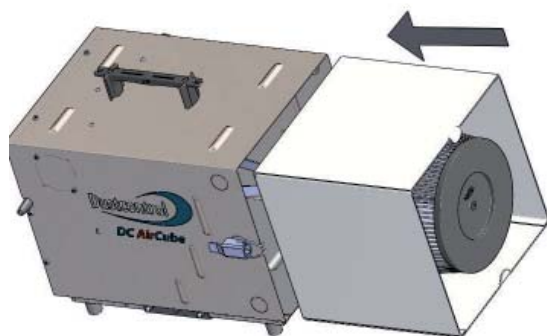

Montage of prefilter:

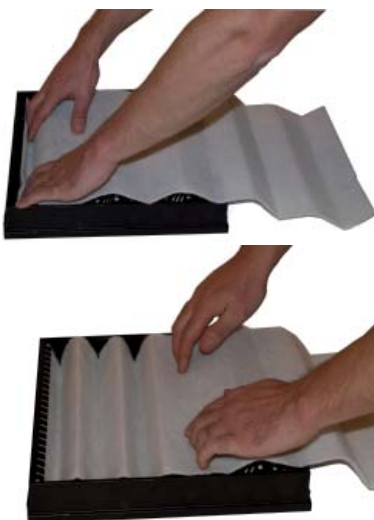

2011-08-23

Check regularly that the electrical cable is not damaged in any way. With replacement of the cable and contact, use only water proof replacements.

The DC AirCube 500 should be performance tested and checked at least once per year or more frequently if subject to intensive use.

Because this machine is used with dangerous sub-stances maintenance is vital, worn parts should be replaced. Never compromise the function of the DC AirCube 500, use only original spare parts. The fan is maintenance free.

- When light is on, it's time for service!

Change of prefilter:



Change of HEPA filter:

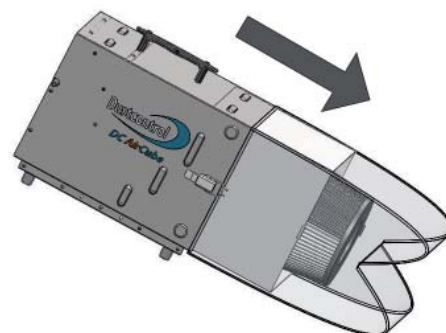

DC AirCube 500 - 11

Part No 94156

## Get In Touch

Call: 0845 6880112  
Email: [info@adremit.co.uk](mailto:info@adremit.co.uk)

## Our Address

Puravent, Adremit Limited, Unit 5a, Commercial Yard, Settle, North Yorkshire, BD24 9RH

# Accessories

Description	Part no
Hose $\phi$ 125 mm	2420
Hose clamp	4138
Prefilter	42690
Microfilter	42692
Funnel	42753
Bracket	42724

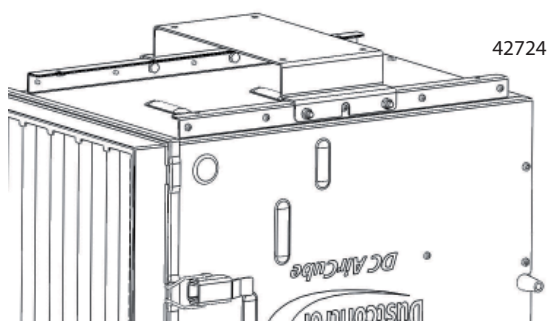
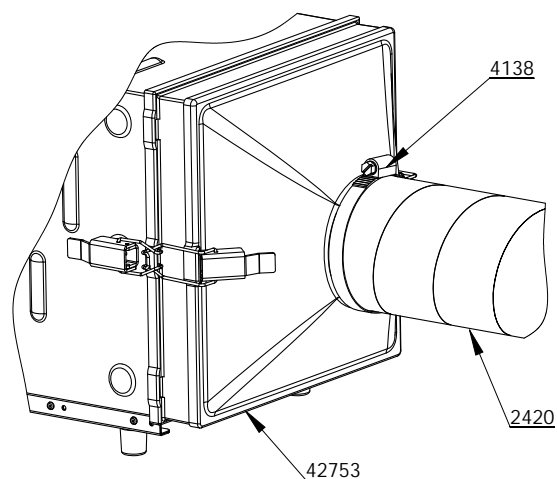

Other accessories — see Dustcontrol catalogue.

# Warranty

The warranty period for this machine is two years and covers manufacturers faults. The warranty is valid under the condition that the machine is used under normal conditions on the task for which it was designed and is maintained properly. Normal wear is not covered by this warranty.

Service performed by other than Dustcontrol or its authorized agent voids automatically the warranty. No other warranty express or implied is applicable.

## TROUBLE SHOOTING

Problem	Fault	Solution
Machine blows dust.	Damaged filter or gasket.	Change filter.
Machine runs only on one speed.	Condenser is faulty.	Order parts and replace.
Reduction in airflow at exhaust.	Filled filter.	Change filter.
Fan does not start.	No power.	Check power source and connection.

### Get In Touch

Call: 0845 6880112  
 Email: [info@adremit.co.uk](mailto:info@adremit.co.uk)

### Our Address

Puravent, Adremit Limited, Unit 5a, Commercial Yard, Settle, North Yorkshire, BD24 9RH