

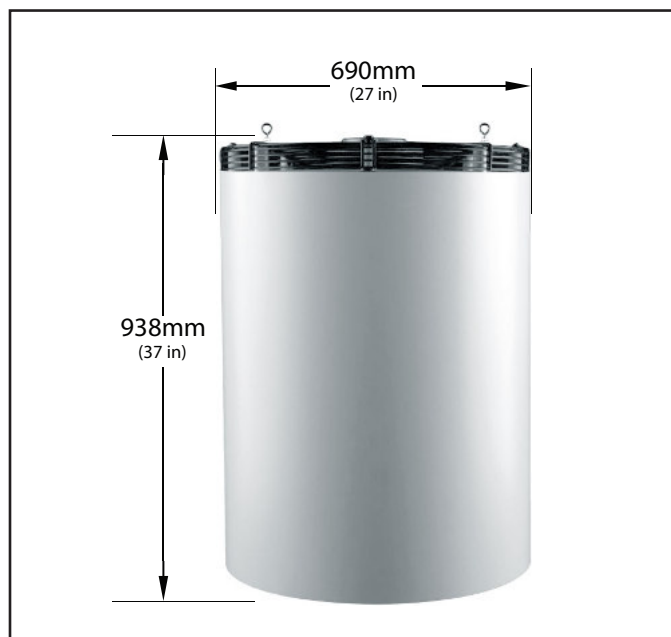

## DIMENSIONS



## PROPERTIES

UNIT SIZE	Standard	
	Weight:	45.3 kgs (100 lbs)
	Height to Rim:	N/A
	Total Height:	938 mm (37 in)
Diameter:		690 mm (27 in)

MOTOR	200V - 277V	
	Watts* @ 50 hz:	400
	RPM* @ 50 hz:	1,000
	CFM* @ 50 hz (m3/hr):	5,200 (8,835)
	AMPS* @ 50 hz:	1.80

\*Motor data provided by motor manufacturer and is subject to change at anytime

### COVERAGE

- Ceiling Height = 20m - 35m (66 - 114.5 ft)
- Diameter = 17m - 21m (56 - 69 ft)
- Floor area = 223m<sup>2</sup> - 334m<sup>2</sup> (2,400- 3,595 ft<sup>2</sup>)

### MOTOR

- Single phase, electrically commutated, variable speed (with optional speed control), 92% efficient motor
- Sealed bearings, no lubrication required

### OPERATING TEMPERATURES

- Operating Temp = -25°C (-13°F) to 60°C (140°F)
- Thermal shut off = 135°C (275°F)
- Reset = 125°C (255°F)

### HOUSING

- Aluminium cylindrical housing
- Powder coated
- Internal aluminium fixed blade stator
- 5VA flame rating

### NOISE LEVEL

- Floor Level = 0 - 31 dB(A)

### INGRESS PROTECTION

- IP54 Rated

### COLOUR

- Cool gray 2C - Off white as standard
- Can be tailor painted to your colour specifications

### ACCESSORIES & OPTIONS

- Speed Controls - On/off speed controls allow for variable output from Airius unit. EC controls available

### WARRANTY

- 5 years parts and workmanship from shipping date
- 120 day money back guarantee (T's & C's apply)

### Get In Touch

Call: 0845 6880112  
Email: [info@adremit.co.uk](mailto:info@adremit.co.uk)

### Our Address

Puravent, Adremit Limited, Unit 5a, Commercial Yard,  
Settle, North Yorkshire, BD24 9RH

## PLACEMENT

### PREPARATION

- Install electrical circuit(s) and outlet(s) in accordance with national and local electric codes
- Outlets should generally be mounted vertically unless a "twist/locking" type is being used
- Wall switch may be installed in circuit to disable power and prevent electrical hazards when servicing
- Confirm electrical continuity of Airius unit on the ground before permanently mounting in the ceiling

### INSTALLATION

- Hang vertically as high in the ceiling as possible  
Typically 300mm (12") - 450mm (18") from the roof deck to intake
- The Airius unit performs best when air column from the nozzle is unimpeded to the floor
- Use professionally installed hardware, capable of supporting a minimum of five times the weight
- Hardware to hang the unit includes but is not restricted to: Hooks, chains, cables, carabiners, bridle rings, beam clamps and bolts
- Density of the placement is directly related to the effectiveness, performance and savings
- Mount out of reach from people and animals
- Floor plans, mezzanines, office locations, machinery, people placement, plumbing, lighting, duct work, electrical systems, natural light/air systems, cranes, doors, windows, ventilation and fire suppression systems are all factors in properly locating the Airius system within the ceiling

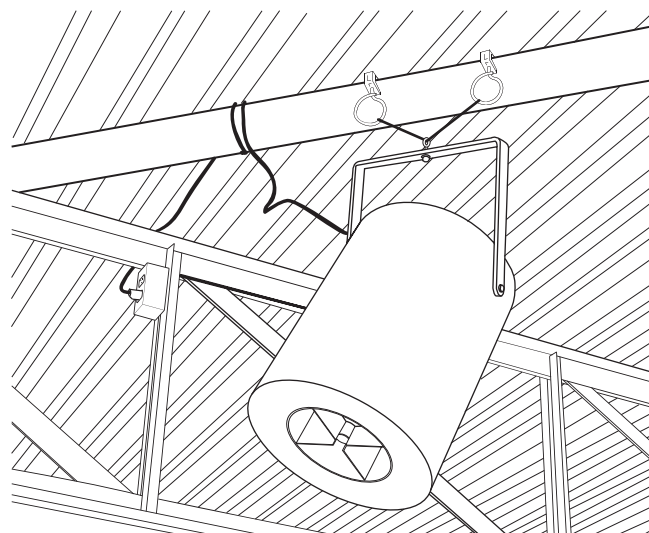

### OPERATION

- Designed to operate 24 hours-a-day, 7 days-a-week to maintain thermal equalization/humidity equalization
- Use optional speed control to fine tune RPM if needed

### MAINTENANCE

- Frequency of cleaning will vary by application and environment
- You may clean the plastic housing with a damp warm cloth, using mild household detergents
- Do not use petroleum products, thinners or solvents to clean any part of the Airius unit
- If the Airius unit fails, contact manufacturer



Airius LLC, © 2011. All Rights Reserved.

Airius Europe Ltd

Holwell Farm, Cranborne, Dorset BH21 5QP

[www.airius.co.uk](http://www.airius.co.uk)

+44 (0)1202 554200

### Get In Touch

Call: 0845 6880112

Email: [info@adremit.co.uk](mailto:info@adremit.co.uk)

### Our Address

Puravent, Adremit Limited, Unit 5a, Commercial Yard,  
Settle, North Yorkshire, BD24 9RH